

FL503CS



APLICACIONES

Las bombas centrífugas sanitarias FL503CS se utilizan principalmente en procesos de la industria alimentaria, farmacéutica y cosmética.

CARACTERISTICAS

- Nivel de acabados sanitarios
- Rodete abierto
- Cierre sanitario
- Fácil limpieza

CURVAS DE RENDIMIENTO BOMBA FL503CS

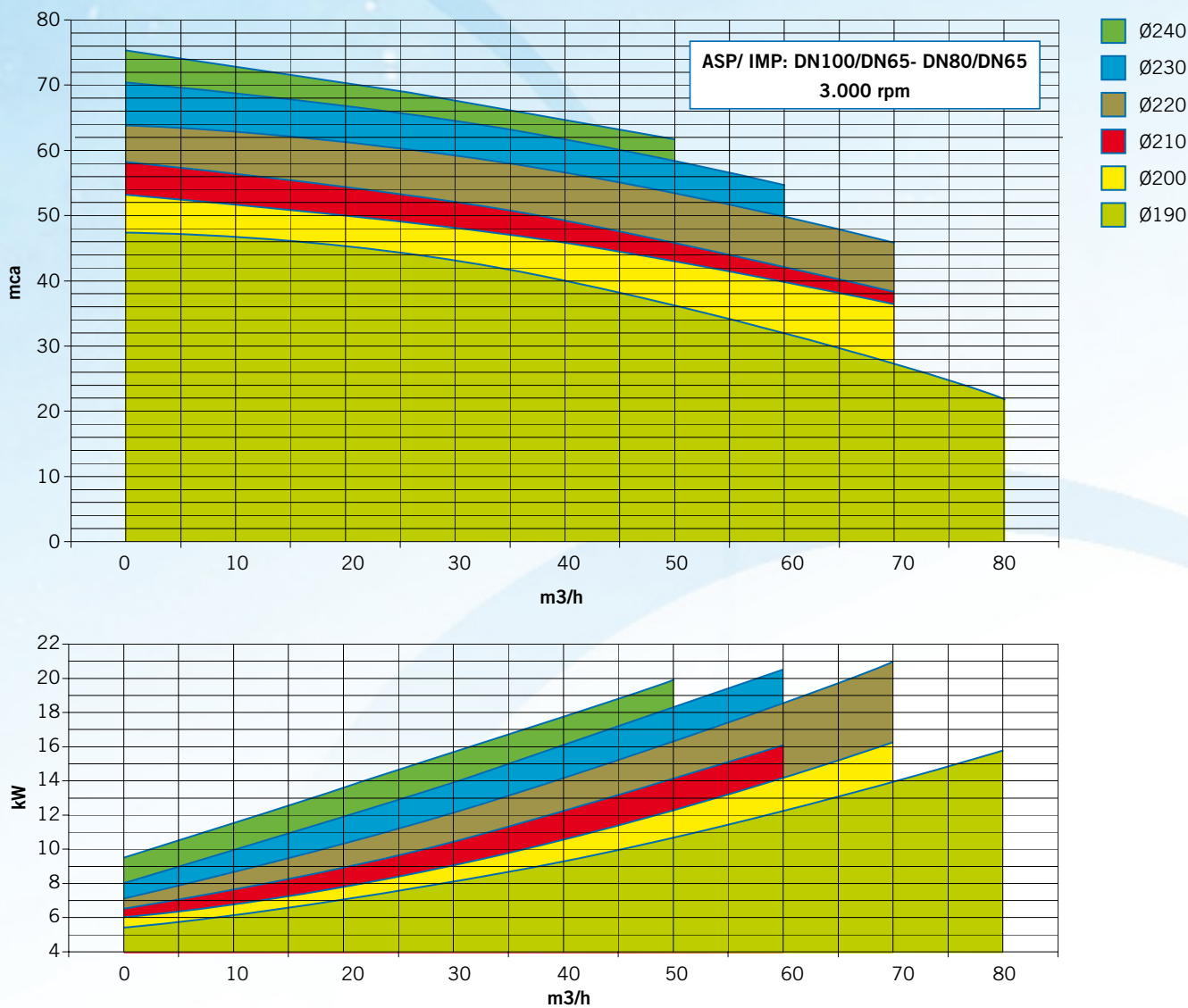

(para otras combinaciones de rodete y potencia consultar)

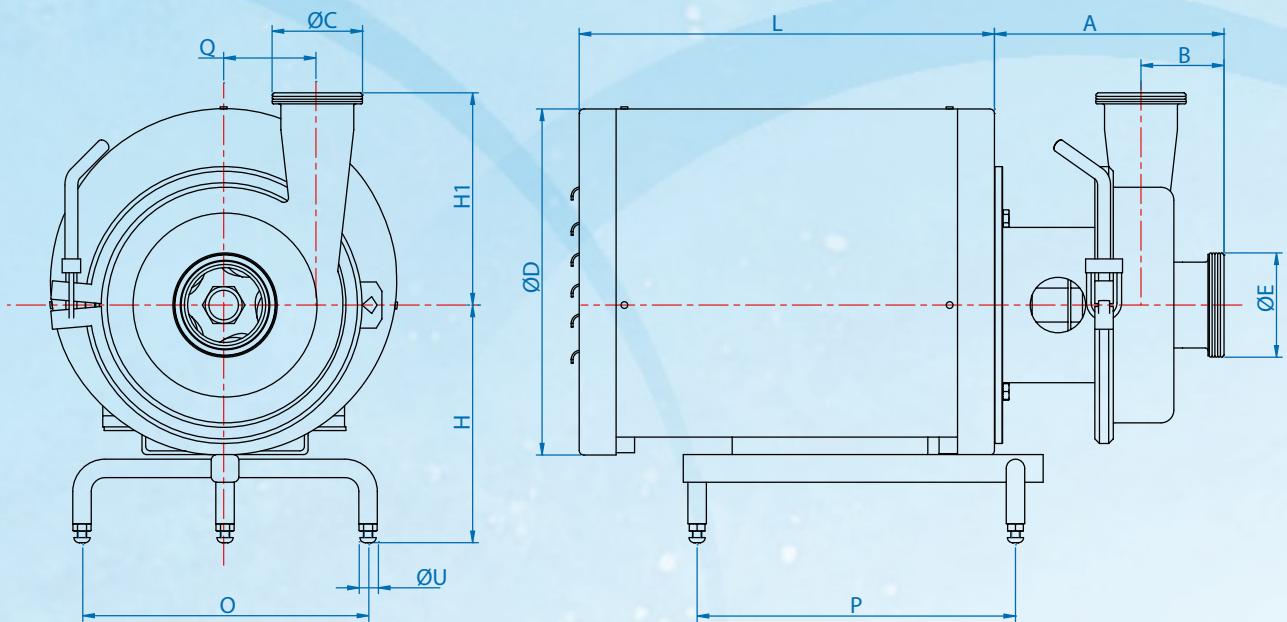

MODELO	MOTOR		DIMENSIONES											
	CV	KW	A	B	C	D	E	H	H1	L	O	P	Q	U
FL503CS	7.5	5.5	250	90	NW65	Ø325	NW80	242	230	390	290	345	100	Ø18
	9	7.5				Ø375		262		450				
	12	9				Ø475		290		550				
	15	11	275			NW100	290	370		475				
	18.5	15					310							
	25	18.5												
30	22													

LISTADO DE MATERIALES

BOMBA

Linterna, recubrimiento y trípode

ACERO INOXIDABLE AISI304

Cuerpo

Rodete

Eje

Conducciones

ACERO INOXIDABLE AISI316

CIERRE MECANICO

Parte fija

Inox.

Silicio

Inox.

Parte rotativa

Grafito

Silicio

Grafito

Juntas

NBR

Vitón

EPDM

(Para demás materiales consultar)

MOTOR

Protección IP55

50 Hz 220-380V/380-420V