



English

# Installation, Operation and Maintenance Instructions

E Range  
Size OX4 and above

**SURPLUS**

**SELECT**

**USED MACHINERY**

# Spares & Service Contact Details

## Mono UK

<b>Spares</b>	+44 (0)161 214 2380 (direct line 8.15 am – 5.00 pm)
<b>E-mail</b>	spares@mono-pumps.com
<b>Service</b>	+44 (0)161 214 2390 (direct line 8.15 am – 5.00 pm)
<b>E-mail</b>	customerservices@mono-pumps.com
<b>Service</b>	+44 (0)161 339 9000 (24 hrs)

## Mono Australia

	<b>Telephone</b>	<b>Facsimile</b>
<b>Melbourne</b>	(03) 9580 5211	(03) 9580 9036
<b>Sydney</b>	(02) 9521 5611	(02) 9542 3649
<b>Brisbane</b>	(07) 3350 4582	(07) 3350 3750
<b>Adelaide</b>	(08) 8447 8333	(08) 8447 8373
<b>Perth</b>	(08) 9479 0444	(08) 9479 0400
<b>Darwin</b>	(08) 8984 3099	(08) 8947 0540
<b>Tasmania</b>	(03) 6249 8704	(03) 6249 8756
<b>E-mail</b>	ozsales@mono-pumps.com	

## Mono New Zealand

<b>Spares &amp; Service</b>	+64 (0)9 829 0333
<b>E-mail</b>	info@mono-pumps.co.nz

## Monoflo USA

<b>Spares &amp; Service</b>	+1 713 466 7999
<b>E-mail</b>	inquire@monoflo.com

## Mono China

	<b>Telephone</b>	<b>Facsimile</b>
<b>Beijing</b>	+86 (0) 10 6461 1115	+86 (0) 10 8486 8481
<b>Shanghai</b>	+86 (0) 21 5915 7168	+86 (0) 21 5915 6863
<b>E-mail</b>	info@mono-pumps.com	

# ATEX Warning Statements

## PUMPS AND PUMP UNITS

Where a pump or pump unit is to be installed in a potentially explosive atmosphere ensure that this has been specified at the time of purchase and that the equipment has been supplied accordingly and displays an ATEX nameplate or is supplied with a certificate of conformity. If there is any doubt as to the suitability of the equipment please contact Mono Pumps Limited before commencing with installation and commissioning.

Process liquids or fluids should be kept within specified temperature limits otherwise the surface of pump or system components may become an ignition source due to temperature rises. Where the process liquid temperature is less than 90°C the maximum surface temperature will not exceed 90°C provided the pump is installed, operated and maintained in accordance with this manual. Where the process fluid temperature exceeds 90°C the maximum surface temperature will be equal to the maximum process fluid temperature.

Cavities that could allow the accumulation of explosive gases, such as under guards, should where possible, be designed out of the system. Where this is not possible they should be fully purged before any work is carried out on the pump or system.

Electrical installation and maintenance work should only be carried out by suitably qualified and competent persons and must be in accordance with relevant electrical regulations.

All electrical equipment, including control and safety devices, should be suitably rated for the environment in to which they are installed.

Where there may be a risk of an accumulation of explosive gases or dust non-sparking tools should be used for installation and maintenance.

In addition to causing permanent damage to the stator, dry running of the pump could generate a rapid rise in the temperature of the stator tube or barrel, which could become an ignition source. It is therefore essential that a dry run protection device be fitted. This must shut the pump down immediately should a dry run situation occur. Details of suitable devices are available from Mono Pumps Limited.

To minimise the risk of sparking or temperature rises due to mechanical or electrical overload the following control and safety devices should be fitted in addition to a dry run protection system. A pressure relief system whereby the pump can not generate pressures in excess of the maximum rated pressure or an over pressure device which should shut the pump down when the maximum discharge pressure is exceeded. A control system that will shut the pump down if the motor current or temperature exceed specified limits. An isolator switch that will disconnect all electrical supply to the motor and ancillary electrical equipment and be capable of being locked in the off position. All control and safety devices should be fitted, operated and maintained in accordance with the manufacturer's instructions. All valves on the system should be open when the pump is started otherwise serious mechanical overload and failure may result.

It is important that the pump rotates in the direction indicated on the nameplate. This must be checked on installation and commissioning and after any maintenance has been carried out. Failure to observe this may lead to dry running or mechanical or electrical overload.

# ATEX Warning Statements

When fitting drives, couplings, belts, pulleys and guards to a pump or pump unit it is essential that these are correctly fitted, aligned and adjusted in accordance with the manufacturer's instructions. Failure to do so may result in sparking due to unintended mechanical contact or temperature rises due to mechanical or electrical overload or slipping of drive belts. Regular inspection of these parts must be carried out to ensure they are in good condition and replacement of any suspect part must be carried out immediately.

Mechanical seals should be suitably rated for the environment. The seal and any associated equipment, such as a flushing system, must be installed, operated and maintained in accordance with the manufacturer's instructions.

Where a packed gland seal is fitted this must be correctly fitted and adjusted. This type of seal relies on the process liquid to cool the shaft and packing rings so a constant drip of liquid from the gland section is required. Where this is undesirable an alternative seal type should be fitted.

Failure to operate or maintain the pump and ancillary equipment in line with the manufacturer's instructions may lead to premature and potentially dangerous failure of components. Regular inspection, and where necessary replacement, of bearings and lubrication is essential.

The pump and its components have been designed to ensure safe operation within the guidelines covered by legislation. Accordingly Mono Pumps Limited have declared the machine safe to use for the duty specified as defined by the Declaration of Incorporation or Conformity that is issued with this instruction manual.

The use of replacement parts that are not manufactured by or approved by Mono Pumps Limited may affect the safe operation of the pump and it may therefore become a safety hazard to both operators and other equipment. In these circumstances the Declaration provided will become invalid. The guarantee referenced on the Terms and Conditions of Sale will also be invalidated.

# Special Tools

<u>Pump Size</u>	<u>Tool Set</u>	<u>Extractor Bolt (Shaft)</u>	<u>Extractor Screw (Rotor Adaptor)</u>	<u>Extractor Tool</u>
E041	21101	MS E041 9700	N/A	MS E041 9710
E04K				
E036	21102	MS E051 9700	N/A	MS E051 9710
E038				
E042				
E051				
E05K				
E0X4				
E044				
E052	21103	MS E061 9700	N/A	MS E061 9710
E061				
E06K				
E054	21104	MS E081 9700	N/A	MS E081 9710
E062				
E071				
E07K				
E081				
E08K				
E064				
E072	21105	MS E081 9700	N/A	MS E101 9710
E082				
E091				
E09K				
E101				
E10K	21106	MS E121 9700	MO E121 9701	MS E121 9710
E084				
E092				
E102				
E103				
E121				
E12K	21107	MS E121 9700	MO E074 9701	MS E074 9710
E074				
E122	21108	MS E121 9700	MO E151 9701	MS E151 9710
E151				
E161				
E152	23903	MO E201 9701	MO E201 9700	MS E201 9710
E153				
E201				

# Index

<b>SECTION 1</b>	<b>INSTALLATION</b>
	<b>START-UP PROCEDURE</b>
	<b>ASSEMBLY AND DISMANTLING ADVICE</b>
<b>SECTION 2</b>	<b>FAULT FINDING</b>
<b>SECTION 3</b>	<b>DRAWING REFERENCE NUMBERS</b>
	<b>PUMP CODING SHEET</b>
<b>SECTION 4</b>	<b>DISMANTLING AND ASSEMBLY DIAGRAMS</b>
	<b>EXPLODED VIEWS</b>
<b>SECTION 5</b>	<b>TORQUE TIGHTENING FIGURES</b>
<b>SECTION 6</b>	<b>MONO PRODUCTS</b>

## EC Declaration as defined by Machinery Directive 98/37/EC.

### EC Declaration of Incorporation

This declaration is only valid when the machinery has been supplied without drive unit.

In this case, the machinery meets the requirements of the said directive and is intended for incorporation into other machinery or for assembly with other machinery in order to constitute relevant machinery as defined by the said directive including any amendments, which are valid at the time of supply.

### **IMPORTANT**

This machinery must not be put into service until the relevant machinery into which it is to be incorporated has been declared in conformity to the said directive.

This declaration is only valid when the machinery has been installed, operated and maintained in accordance with these instructions and safety guidelines contained within as well as instructions supplied for equipment assembled with or intended for use with this equipment.

The following harmonised standards are applicable:

BS EN 809

BS EN ISO 12100 Parts 1 & 2

### EC Declaration of Conformity

This declaration is only valid when the machinery has been supplied with drive unit.

In this case the machinery meets the requirements of the said directive including any amendments which are valid at the time of supply.

### **IMPORTANT**

This declaration is only valid when the machinery has been installed, operated and maintained in accordance with these instructions and safety guidelines contained within as well as instructions supplied for equipment assembled with or intended for use with this equipment.



Mr G.D. Thomas, Chief Engineer

# Installation, Operation & Maintenance Instructions

## INSTALLATION

### 1.1 INSTALLATION AND SAFETY RECOMMENDATIONS

In common with other items of process plant a pump must be installed correctly to ensure satisfactory and safe operation. The pump must also be maintained to a suitable standard. Following these recommendations will ensure that the safety of personnel and satisfactory operation of the pump is achieved.

#### 1.2.1. GENERAL

When handling harmful or objectionable materials, adequate ventilation must be provided in order to disperse dangerous concentrations of vapours. It is recommended that wherever possible, Mono pumps should be installed with provision for adequate lighting, thus ensuring that effective maintenance can be carried out in satisfactory conditions. With certain product materials, a hosing down facility with adequate draining will simplify maintenance and prolong the life of pump components.

#### 1.2.2. SYSTEM DESIGN & INSTALLATION

At the system design stage, consideration must be given to provision of filler plugs, and the installation of non-return and/or isolating valves. Pumps cannot be reliably used as non-return valves. Pumps in parallel and those with high static discharge head must be fitted with non-return valves.

The pumps must also be protected by suitable devices against over pressure and dry running.

#### i. HORIZONTAL MOUNTING

All ranges excluding P Range Mono pumps are normally installed in a horizontal position with baseplates mounted on a flat surface, grouted in and bolted, thus ensuring firm fixing and a reduction in noise and vibration.

The unit should be checked after bolting down to ensure that the alignment of the pump to its prime mover is correct.

#### ii. VERTICAL MOUNTING

P Range Pumps Only

The P range pumps are intended for vertical installation. Care must be taken when lifting the pump into the vertical position.

Normally 'P' range pumps will be designed with a sole plate that will be bolted to the customers framework.

If the pump is to be mounted in any way other than described above, confirmation of the installation must be agreed with Mono Pumps Limited. All the pipework should be independently supported.

#### 1.3.1 HANDLING



During installation and maintenance, attention must be paid to the safe handling of all items. Where a pump or its components weigh in excess of 20 kg (45lb) it is recommended that suitable lifting tackle should be used to ensure that personal injury or damage to components does not occur.

For safe handling of both bareshaft pumps and pump units (pump/ gearbox/motor etc.) slings should be used. The position of the slings will depend upon the specific pump/unit construction and should be carried out by personnel with the relevant experience to ensure that the pump is not damaged and injury to personnel does not occur.

If eyebolts do exist then these should only be used for lifting the individual components for which they are supplied.

#### 1.3.2 STORAGE AND INFREQUENT OPERATION

The situation where a pump is used infrequently is also covered by the instructions in this section.

##### SHORT TERM STORAGE

**Where a pump has to be stored for 6 months or less then the following steps are advised:-**

1. Store pump inside wherever possible or if this is not feasible then provide protective covering. Do not allow moisture to collect around the pump.
2. Remove the drain plug, if fitted. Any inspection plates fitted should also be removed to ensure that the suction housing can drain and dry completely.
3. Loosen the packed gland and inject sufficient grease into the stuffing box. Tighten the gland nut hand tight. If a water flush system is to be used do not grease, a small amount of light oil is recommended for these.
4. See Manufacturers Instructions for motor/gearbox/drive instructions for storage procedures.

# Installation, Operation & Maintenance Instructions

## LONG TERM STORAGE

**If the pump is to be kept in storage for more than six months then in addition to the above the following procedures should be carried out regularly (every 2 - 3 weeks if possible):**

1. If practicable rotate the pump at least three quarters of one revolution to avoid the rotor setting in the stator.
2. Note, however, that the pump is not to be rotated for more than two revolutions each time because damage could be caused to the rotor/ stator elements.

## IMMEDIATELY PRIOR TO INSTALLATION AND STARTING

**Before installing the pump please ensure that all plugs and inspection plates are replaced and that excess grease/oil is removed from the stuffing box.**



### 1.4 ELECTRICAL



Electrical connection should only be made using equipment suitable for both rating and environment. Where any doubts exist regarding the suitability of equipment, Mono Pumps Limited, should be consulted before proceeding. Normally the Mono pump should be installed with starting equipment arranged to give direct on line starting.

Earthing points will be provided on electric drives (if supplied) and it is essential that these are correctly connected. When the motor is being wired and checked for rotation, the start/stop sequence must be instantaneous to prevent dry running (see 2) or pressurising upstream equipment. (Check direction arrow on pump nameplate). The electrical installation should include appropriate isolating equipment to ensure that the pump unit is safe to work on.

### 1.5 PRESSURE RELIEF VALVES AND NON-RETURN VALVES

1. It is recommended that a suitable safety device is installed on the discharge side of the pump to prevent over-pressurisation of the system.
2. It is also recommended that a non-return valve is installed on the discharge side of the pump to prevent reverse flow through the system.

When both are installed it is advised that the relief valve is positioned closer to the pump than the non-return valve.

## IMPORTANT



**The pump must never run against a closed inlet or outlet valve, as this could result in mechanical failure.**

### 1.6 GENERAL SAFETY



**GREAT CARE MUST BE TAKEN TO PROTECT ALL ELECTRICAL EQUIPMENT FROM SPLASHING WHEN HOSING DOWN. WHERE MONO PUMPS LIMITED HAVE SUPPLIED A BARESHAFT PUMP THE ONUS IS ON THE USER TO FIT ADEQUATE GUARDS IN COMPLIANCE WITH THE REQUIREMENTS OF THE RELEVANT REGULATIONS.**

All nuts and bolts, securing flanges and base mounting fixtures must be checked for tightness before operation. To eliminate vibration, the pump must be correctly aligned with the drive unit, and all guards must be securely fixed in position. When commissioning the plant, all joints in the system must be checked thoroughly for leakage.

If, when starting, the pump does not appear to operate correctly (see 2), the plant must be shut down immediately and the cause of the malfunction established before operations are recommenced. It is recommended that depending upon plant system operation, either a combined vacuum and pressure gauge, or a vacuum gauge only be fitted to the pump inlet port, and a pressure gauge fitted to the outlet port, these will then continuously monitor the pump operating conditions.

### 1.7 DUTY CONDITIONS

Pumps should only be installed on duties for which Mono Pumps Limited have specified the materials of construction, flow rates, pressure, temperature, speed etc. Where dangerous materials are to be pumped, consideration must be given to the safe discharge from relief valves, gland drains etc.

**IF THE DUTY SHOULD BE CHANGED, MONO PUMPS LIMITED SHOULD BE CONTACTED AND THEIR RECOMMENDATIONS SOUGHT IN THE INTEREST OF APPLICATION, SAFETY OF PLANT, EFFICIENCY AND PUMP LIFE.**

# Installation, Operation & Maintenance Instructions

## 2. START-UP PROCEDURE

Pumps must be filled with liquid before starting. The initial filling is not for priming purposes, but to provide the necessary lubrication of the stator until the pump primes itself. When the pump is stopped, sufficient liquid will normally be trapped in the rotor/stator assembly to provide lubrication upon re-starting.

If, however, the pump has been left standing for an appreciable time, moved to a new location, or has been dismantled and re-assembled, it must be refilled with liquid and given a few turns before starting. The pump is normally somewhat stiff to turn by hand owing to the close rotor/stator fit. However, this stiffness disappears when the pump is running normally against pressure.

### 2.1 DRY RUNNING



**NEVER RUN THE PUMP IN A DRY CONDITION EVEN FOR A FEW REVOLUTIONS OR THE STATOR WILL BE DAMAGED IMMEDIATELY. CONTINUAL DRY RUNNING COULD PRODUCE SOME HARMFUL OR DAMAGING EFFECTS.**

### 2.2 PUMP ROTATION DETAILS

<u>PUMP RANGE</u>	<u>BI-DIRECTIONAL</u>	<u>COMMENT</u>
E	Yes	†
Monobloc B	Yes	†
Merlin Industrial	Yes	†
S, SL	Yes	†
LF	Yes	†
W	No	**
Merlin Widethroat	No	**
MM ML	No	*
MS	No	**
G	No	*
CB/SB	No	*
Placer	No	**
Grout Injection	No	**
P	No	*
CP0011	No	**
CP0025,CP0800,CP1600	No	*

- \* Clockwise when viewed from drive end.
- \*\* Anti-clockwise when viewed from drive end.
- † Anti-clockwise gives inlet at drive end.

### DIRECTIONS OF ROTATION



**BEFORE THE DIRECTION OF ROTATION IS CHANGED, MONO PUMPS LIMITED MUST BE CONSULTED SO THAT THE SUITABILITY OF THE PUMP CAN BE CONFIRMED WHEN OPERATING ON THE NEW DUTY.**

### 2.3.1. GLAND PACKING

Where a pump is supplied fitted with gland packing (manufactured from a non-asbestos material), the gland will require adjustment during the initial running in period. Newly packed glands must be allowed to run-in with only finger tight compression on the gland follower nuts. This should continue for about 3 days. The gland follower should be gradually tightened over the next week to achieve a leakage rate as shown in the table below. Gland followers should be adjusted at regular intervals to maintain the recommended leakage flow rate. Under normal working conditions a slight drip from the gland under pressure assists in cooling and lubricating the packing. **A correctly adjusted gland will always have small leakage of fluid.**

#### Typical Leakage Rates from Packed Glands

<u>Up to 50mm shaft diameter</u>	<u>2 drops per minute</u>
<u>50 ... 75mm shaft diameter</u>	<u>3 drops per minute</u>
<u>75 ... 100mm shaft diameter</u>	<u>4 drops per minute</u>
<u>100 ... 125mm shaft diameter</u>	<u>5 drops per minute</u>
<u>125 ... 160mm shaft diameter</u>	<u>6 drops per minute</u>

A gland drip is, however, undesirable when handling corrosive, degreasing, or abrasive materials. Under these conditions the gland must be tightened the minimum amount whilst the pump is running to ensure satisfactory sealing when under pressure, or to stop entry of air when under suction conditions.

The gland leakage of toxic, corrosive or hazardous liquids can cause problems of compatibility with the pumps materials of construction.

Provision of a gland drain should be considered, especially for the leakage of hazardous products.



**CARE IS REQUIRED WHEN ADJUSTING THE GLAND WHILST PUMP IS RUNNING.**

### 2.3.2 MECHANICAL SEALS - ALL PUMPS

When a mechanical seal is fitted to the pump it may be necessary to provide a barrier fluid to some part of the seal. This should be provided in line with the seal manufacturers instructions.

### 2.4. GUARDS



In the interests of safety, and in accordance with the U.K. Health and Safety at Work Act 1974, all guards must be replaced after necessary adjustments have been made to the pump.

# Installation, Operation & Maintenance Instructions

## 2.5 WARNING/CONTROL DEVICE

Prior to operating the pump, if any warning or control devices are fitted these must be set in accordance with their specific instructions.

## 2.6 PUMP OPERATING TEMPERATURE

The range of temperatures the pump surfaces will develop is dependent upon factors such as product temperature and ambient temperature of the installation. There may be instances where the external pump surface can exceed 50°C.

In these instances, personnel must be made aware of this and suitable warnings/guarding used.

## 2.7 NOISE LEVELS

1. The noise sound pressure level will not exceed 85dB at one metre distance from the pump.
2. This is based on a typical installation and does not necessarily include noise from other sources or any contribution from building reverberation.
3. For pumps identified below, the noise levels vary between 85 and 95dB but will not exceed 95dB at one metre distance from the pump.

### Pump Sizes (based on E Range Pumping Element)

Single Stage	Size 12 and above
Two Stage	Size 9 and above
Four Stage	Size 7 and above
Six Stage	Size 7 and above
Eight Stage	Size 6 and above

## 2.8 LUBRICATION

Pumps fitted with bearings should be inspected periodically to see if grease replenishment is necessary, and if so, grease should be added until the chambers at the ends of the bearing spacer are approximately one third full.

Periodic bearing inspection is necessary to maintain optimum bearing performance. The most expedient time to inspect is during periods of regular scheduled equipment downtime - for routine maintenance or for any other reason.

Under tropical or other arduous conditions, however, a more frequent examination may be necessary. It is therefore advisable to establish a correct maintenance schedule or periodic inspection.

BP LC2 / Mobilgrease XHP 222 or their equivalent must be used for replenishment.

## 2.9 PUMP UNITS

Where a pump unit is dismantled and re-assembled, consideration must be given to ensure that where appropriate the following steps are covered.

1. Correct alignment of pump/gearbox
2. Use of appropriate couplings & bushes
3. Use of appropriate belts & pulleys correctly tensioned.

## 2.10 CLEANING PRIOR TO OPERATION

### i. Non Food Use

During the commissioning of a new pump or recommissioning of an overhauled pump, it is advisable to clean the pump prior to the initial operation of the pump in the process.

### ii. Food Use

When a pump has been supplied for a food application, it is important to ensure that the pump is clean prior to initial operation of the pump.

Therefore, it is important that a clean-in-place treatment is executed on the pump at the following times:-

1. When the pump is first commissioned for use.
2. When any spare components are fitted into the wetted area of the pump.

A recommended CIP procedure is as follows:

**This procedure should not be used on the CP Pump Range. Please consult our application engineers for a suitable procedure.**

### Caustic Wash

LQ94 ex Lever Diversey or equivalent  
2% concentration

### Acid Wash

P3 Horolith 617 ex Henkel  
Ecolab or equivalent 1% concentration

### Procedure

1. Caustic wash @ 75°C for 20 mins
2. Water rinse @ 80°C for 20 mins

# Installation, Operation & Maintenance Instructions

3. Acid wash @ 50°C for 20 mins
  4. Water rinse @ 80°C for 20 mins
- CIP flow rates (hence pump speeds) should be maximised to achieve highest level of cleanability.

A C.I.P. liquid velocity of 1.5 to 2.0 m/s is required for removal of solids and soiling.

Pumps fitted with CIP by pass ports will permit higher flow rates without the need to increase pump speed.

- The use of neat active caustic and acid chemicals is not recommended. Proprietary cleaning agents should be used in line with manufacturers instructions.
- All seals and gaskets should be replaced with new if disturbed during maintenance.
- Pump internals should be regularly inspected to ensure hygienic integrity is maintained, especially with respect to elastomeric components and seals, and replaced if necessary.

The four stages constitute one cycle and we recommend that this cycle is used to clean the pump before use on food.

Once the pump has been commissioned, the cleaning process will depend upon the application. The user must therefore ensure that their cleaning procedures are suitable for the duty for which the pump has been purchased.

## 2.11 WIDETHROAT PUMPS

Specific pumps may have auger feed screws, with or without a bridge breaker system to feed the pumping element. If the pump installation requires that these cannot be enclosed, care must be taken to ensure personnel cannot gain access whilst the pump is operating. If this is not possible an emergency stop device must be fitted nearby.

## 2.12 EXPLOSIVE PRODUCTS/ HAZARDOUS ATMOSPHERES

In certain instances the product being pumped may well be of a hazardous nature.

In these installations consideration must be given to provide suitable protection and appropriate warnings to safeguard personnel and plant.

## 2.13 ACCESS PORTS



Where access ports are fitted then the following steps must be followed prior to removal:

1. Pump must be shut down and the electrical supply isolated.
2. Protective clothing should be worn, especially if the pumped product is obnoxious.
3. Remove access plate with care utilising where possible drip trays to collect product leakage.

Access ports are included to assist in removing blockages and to allow a visual check on the components within the suction chamber.

It is not to be considered as an additional method in dismantling the pump.

Re-assembly of the plate should be completed using new gaskets prior to the pump being switched on.

## 2.14 ADJUSTABLE STATORS

If adjustable stators are fitted then the following steps must be followed for adjusting the clamping devices.

The adjustable stator assembly is designed to give an even compression around the stator circumference. It is designed to be used when pump performance reduces through wear to an unacceptable level, to restore the required flow rate.

The stator compression is increased using the following steps:-

1. Release the six locking screws half a turn.
2. Tighten the eight clamp screws until adjustment allowed by releasing the lock screws has been taken up.
3. Repeat steps 1 and 2 until the pump performance has been restored to its former level.

### NOTE

It is imperative that when adjusting the stator that only sufficient pressure is placed on the stator to enable the capacity of the pump to be reinstated.

Over tightening of the stator could easily result in damage to the driver by overload and so extreme care must be taken when carrying out these adjustments.

# Installation, Operation & Maintenance Instructions

It is therefore advisable to make the adjustment while the pump is running and power readings can be monitored.

## REMOVAL OF ADJUSTABLE STATOR

The procedure for removal of an adjustable stator is the same as that of a standard one, except it is necessary to remove the clamp plates before the stator can be twisted off the rotor.

This can be done by undoing the clamp screws; then releasing the clamp plate by using the locking screws as jacking screws to remove the clamp plates.

Re-assembly will be done using the reverse procedure.

## 2.15 MAINTENANCE OF WEARING COMPONENTS

### 2.15.1 ROTOR AND STATOR

The wear rate on these components is dependent on many factors, such as product abrasivity, speed, pressure etc.

When pump performance has reduced to an unacceptable level one or possibly both items will need replacing.

### 2.15.2 DRIVE SHAFT - PACKED GLAND

The wear rate of the gland area is dependent on many factors such as product abrasivity and speed. Regular gland maintenance will maximise the life of the shaft. Replacement of both the gland packing and shaft will be necessary when shaft sealing becomes difficult to achieve.

### 2.15.3 COUPLING ROD JOINTS

Regular maintenance and lubrication will maximise life of the joints.

Replacement of one or both joint assemblies and possibly the coupling rod may be necessary when wear is apparent.

It is essential to replace all the joint items with genuine Mono parts to ensure maximum life.

## 2.15.4 FLEXISHAFT DRIVE PUMPS

With this design there are no wearing items to replace in the drive train, however, if during routine inspection the shaft is visibly damaged / distorted or the protective coating is damaged, then this item should be replaced to avoid unexpected breakdowns.

## 2.16 MECHANICAL SPEED VARIATORS

Refer to the manufacturers instructions.

These machines require regular maintenance, which typically includes weekly adjustment through the full speed range.

## 3.0 ASSEMBLY AND DISMANTLING

Section 4 contains the steps to dismantle and re-assemble the pump. All fastenings must be tightened securely and when identified the appropriate torque figures should be used.

## 3.1 USE OF ITEMS NOT APPROVED OR MANUFACTURED BY MONO PUMPS LIMITED

The pump and its components have been designed to ensure that the pump will operate safely within the guidelines covered by the legislation.

As a consequence Mono Pumps Limited have declared the machine safe to use for the duty specified as defined by the Declaration of Incorporation or Conformity that is issued with this Instruction Manual.

The use of replacement items that are not approved by or manufactured by Mono Pumps Limited may affect the safe operation of the pump and it may therefore become a safety hazard to both operators and other equipment. In these instances the Declaration provided will therefore become invalid. The guarantee referenced in the Terms and Conditions of Sale will also be invalidated if replacement items are used that are not approved or manufactured by Mono Pumps Limited.



## DISPOSAL OF WORN COMPONENTS

*When replacing wearing parts, please ensure disposal of used parts is carried out in compliance with local environmental legislation. Particular care should be taken when disposing of lubricants.*

# Diagnostic Chart

SYMPTOMS	POSSIBLE CAUSES
1. NO DISCHARGE 2. LOSS OF CAPACITY 3. IRREGULAR DISCHARGE 4. PRIMING LOST AFTER START 5. PUMP STALLS AT START UP 6. PUMP OVERHEATS 7. MOTOR OVERHEATS 8. EXCESSIVE POWER ABSORBED BY PUMP 9. NOISE AND VIBRATION 10. PUMP ELEMENT WEAR 11. EXCESSIVE GLAND OR SEAL WEAR 12. GLAND LEAKAGE 13. SEIZURE	1. 2. 3. 7. 26. 28. 29. 3. 4. 5. 6. 7. 8. 9. 10. 22. 13. 16. 17. 21. 22. 23. 29 3. 4. 5. 6. 7. 8. 13. 15. 29. 3. 4. 5. 6. 7. 8. 13. 15 8. 11. 24. 8. 9. 11. 12. 18. 20 8. 11. 12. 15. 18. 20. 8. 11. 12. 15. 18. 20 3. 4. 5. 6. 7. 8. 9. 11. 13. 15. 18. 19. 20. 22. 23. 27. 31 9. 11. 12. 14. 25. 30. 13. 14. 9. 11. 12. 20.
LIST OF CAUSES	REMEDIAL ACTIONS
1. INCORRECT DIRECTION OF ROTATION 2. PUMP UNPRIMED 3. INSUFFICIENT N.P.S.H. AVAILABLE 4. PRODUCT VAPORISING IN SUPPLY LINE 5. AIR ENTERING SUPPLY LINE 6. INSUFFICIENT HEAD ABOVE SUPPLY VESSEL OUTLET 7. FOOTVALVE/STRAINER OBSTRUCTED OR BLOCKED 8. PRODUCT VISCOSITY ABOVE RATED FIGURE 9. PRODUCT TEMP. ABOVE RATED FIGURE 10. PRODUCT VISCOSITY BELOW RATED FIGURE 11. DELIVERY PRESSURE ABOVE RATED FIGURE 12. GLAND OVERTIGHT 13. GLAND UNDERTIGHT 14. GLAND FLUSHING INADEQUATE 15. PUMP SPEED ABOVE RATED FIGURE 16. PUMP SPEED BELOW RATED FIGURE 17. BELT DRIVE SLIPPING 18. COUPLING MISALIGNED 19. INSECURE PUMP/DRIVE MOUNTING 20. SHAFT BEARING WEAR/FAILURE 21. WORN PUMP ELEMENT 22. RELIEF VALVE CHATTER 23. R.V. INCORRECTLY SET 24. LOW VOLTAGE 25. PRODUCT ENTERING PACKING AREA 26. DRIVE TRAIN BREAKAGE 27. NEGATIVE OR VERY LOW DELIVERY HEAD 28. DISCHARGE BLOCKED/VALVE CLOSED 29. STATOR TURNING 30. STUFFING BOX 'EATS' PACKING 31. VEE BELTS	1. REVERSE MOTOR 2. BLEED SYSTEM OF AIR/GAS 3. INCREASE SUCTION HEAD OR REDUCE SPEED/TEMP. 4. INCREASE N.P.S.H. AVAILABLE (SEE 3 ABOVE) 5. CHECK PIPE JOINTS/GLAND ADJUSTMENT 6. RAISE VESSEL/INCREASE PIPE SIZE 7. CLEAN OUT SUCTION LINE/VALVES 8. DECREASE PUMP SPEED/INCREASE TEMP. 9. COOL THE PRODUCT 10. INCREASE PUMP SPEED/REDUCE TEMP. 11. CHECK FOR BLOCKAGES IN DELIVERY LINE 12. ADJUST GLAND SEE O&M INSTRUCTIONS 13. ADJUST GLAND SEE O&M INSTRUCTIONS 14. CHECK FLUID FLOWS FREELY INTO GLAND 15. DECREASE PUMP SPEED 16. INCREASE PUMP SPEED 17. RE-TENSION BELTS 18. CHECK AND ADJUST ALIGNMENT 19. CHECK AND TIGHTEN ALL PUMP MOUNTINGS 20. REPLACE BEARINGS 21. FIT NEW PARTS 22. CHECK CONDITION OF VALVE/RENEW 23. RE-ADJUST SPRING COMPRESSION 24. CHECK VOLTAGE/WIRING SIZES 25. CHECK PACKING CONDITION AND TYPE 26. CHECK AND REPLACE BROKEN COMPONENTS 27. CLOSE DELIVERY VALVE SLIGHTLY 28. REVERSE PUMP/RELIEVE PRESSURE/CLEAR BLOCKAGES 29. REPLACE WORN PARTS/TIGHTEN UP STATOR BOLTS 30. CHECK FOR WORN SHAFT AND REPLACE 31. CHECK AND ADJUST TENSION OR REPLACE

# Drawing Reference Numbers

<u>DRG. REF</u>	<u>DESCRIPTION</u>	<u>DRG. REF</u>	<u>DESCRIPTION</u>
01A	BODY	P401	RETANGULAR KEY
01B	BODY ADAPTOR	P402	SEAL RING
06A	NAMEPLATE (SOG)	P403	SEAL RING
06B	NAMEPLATE (DOG)	P404	SEAL RING
08A	GLAND	P405	SKT HD CAP SCREW
10A	GLAND PACKING/MECHANICAL SEAL	P406	SKT HD CAP SCREW
10B	ROTARY SHAFT LIPSEAL (OPTIONAL)	P407	HEX HD SCREW
11A	BEARING COVER	P408	LOCK NUT
15A	THROWER GUARD	P409	LOCK WASHER
20A	GASKET – ADAPTOR	P410	HEX HD BOLT
20B	GASKET – GLAND	P411	STL BRIGHT WASHER
20C	GASKET – ROTOR	P413	TOROIDAL SEAL RING
20D	GASKET – SUCT. CHAMBER/EXT	P414	HT. STL. CSK SOC. SCREW
20E	GASKET – BODY ADAPTOR	P415	SGL COIL ST STL SPR WASHER
20F	GASKET – INSPECTION COVER	P501	TAPER PLUG
20G	GASKET – END COVER EXTENSION	P502	TAPER PLUG
22A	STATOR	P503	HEX NUT
22B	STATOR	P504	SPRING WASHER
23A	SUCTION CHAMBER	P505	PLAIN WASHER
23B	SUCTION CHAMBER EXTN.	P506	HEX NUT
24A	END COVER	P507	SPRING WASHER
24B	END COVER EXTENSION	P508	PLAIN WASHER
25A	ROTOR	P509	HEX HD BOLT/SCREW
26A	FLEXISHAFT	P510	PLAIN WASHER
27A	ADAPTOR – ROTOR	P511	SPRING WASHER
30A	ROTOR CAP	P512	HEX NUT
31A	LOCKING WASHER	P513	SEAL RING
31B	WASHER – ADAPTOR	P514	SEAL RING
32A	SHAFT	P515	HEX HD BOLT/SCREW
35A	BEARING SPACER	P516	HEX NUT
35B	SHAFT SLEEVE	P517	SPRING WASHER
36A	LOCKING COLLAR – SHAFT	P518	PLAIN WASHER
40A	LANTERN RING	P519	STUD/HEX HEAD BOLT
42A	THROWER	P520	HEX NUT
47A	HALF RINGS	P521	SPRING WASHER
59A	COVER PLATE	P522	PLAIN WASHER
59B	INSPECTION COVER PLATE	P523	STUD
62A	SUPPORT FOOT	P524	HEX NUT
62B	SUPPORT FOOT	P525	SPRING WASHER
62C	SUPPORT FOOT	P526	PLAIN WASHER
65A	GLAND SECTION	P527	HEX HD BOLT/SCREW
66A	ABUTMENT RING	P528	SPRING WASHER
76A	ADAPTOR FLANGE	P529	PLAIN WASHER
95A	TIE BAR – STATOR	P530	HEX NUT
95B	TIE ROD	P531	STEEL HEX BOLT
95C	TIE BAR - STATOR	P532	STEEL HEXAGON NUT
97A	SUPPORT CHANNEL	P533	SGL COIL SPRING WASHER
97B	SUPPORT CHANNEL	P534	STEEL BRIGHT WASHER
P101	TAPER ROLLER BRG	P535	STEEL HEX BOLT
P102	TAPER ROLLER BRG	P536	STEEL HEX NUT
P104	ROTARY SHAFT LIP SEAL	P537	SGL COIL SPRG WASHER
P105	HEX HD BOLT/SCREW	P538	STEEL BRIGHT WASHER
P106	HEX NUT	P539	TAPER PLUG
P107	PLAIN WASHER	P550	STL. HEX HD BOLT
P108	SPRING WASHER	P551	WASHER
P109	THREAD CUTTING SCREW	P552	STL. SGL. COIL SPRING WASHER
P110	PLAIN WASHER	P553	STL. BRIGHT WASHER
P111	HEX HD SCREW	P554	STEEL HEXAGON NUT
P112	SPRING WASHER	P555	STL. HEX HD BOLT
P113	RD HD DRIVE SCREW	P556	TAPER WASHER
P114	HYDRAULIC NIPPLE 1/8" NPT	P557	SGL COIL SPRING WASHER
P201	HEX HD BOLT/SCREW	P558	STEEL BRIGHT WASHER
P202	HEX NUT	P559	STEEL HEXAGON NUT
P203	PLAIN WASHER	P560	HT. STL. HEX. BOLT
P204	SKT HD CAP SCREW	P561	HT. STL. HEX. BOLT
P211	TAPER PLUG	P570	STEEL HEX. BOLT
		P571	STEEL HEX. NUT

## **IMPORTANT NOTE**

THE DRAWING REFERENCES SHOWN GIVE THE DESCRIPTION OF ALL THE PARTS DETAILED ON THE SECTIONAL DRAWINGS IN THIS SECTION OF THE BOOK. THEREFORE SOME OF THE REFERENCES MAY NOT BE SHOWN ON ANY ONE.

# Pump Coding

FEATURES	DESCRIPTION	BASIC PUMP CODE										STANDARD VARIATION					
		1	2	3	4	5	6	7	8	9	10	/	12	13	14	15	
BODY MATERIALS	Cast Iron	C															
	Stainless Steel	S															
	Duplex	F															
	Rubber Lined	R															
PUMP DESIGN	Flexishaft - Industrial		E														
MAXIMUM PUMP CAPACITY AT MAXIMUM SPEED AND ZERO PRESSURE	1.3m³/h			0	1												
	3.3m³/h			0	2												
	10m³/h			0	3												
	13m³/h			0	X												
	22m³/h			0	4												
	37m³/h			0	5												
	57m³/h			0	6												
	79m³/h			0	7												
	97m³/h			0	8												
	125m³/h			0	9												
	165m³/h			1	0												
	225m³/h			1	2												
	210m³/h			1	5												
290m³/h			1	6													
420m³/h			2	0													
PUMP STAGES	Low Pressure					K											
	One					1											
	Two					2											
	Three					3											
	Four					4											
	Six					6											
	Eight					8											
	Twelve					C											
END COVER AND DRIVE DESIGN	Str thro E/C, Std Flexishaft						M										
	90° E/C, Std Flexishaft						G										
	Str thro E/C, Special Flexishaft						S										
	90° E/C, Special Flexishaft						T										
MECHANICAL SEAL DUTY CONDITIONS	Light duty with Mk 1 rotor							H									
	Standard duty with Mk 1 rotor							J									
	Standard duty with Mk 0 rotor							K									
	Light duty with Mk 0 rotor							N									
PACKED GLAND DUTY CONDITIONS	Light duty with Mk 1 rotor							L									
	Standard duty with Mk 1 rotor							S									
	Standard duty with Mk 0 rotor							X									
	Light duty with Mk 0 rotor							Z									
DESIGN MARK NUMBER	1989 (1994 Sizes 01-0X) (1996 Low Pressure)									1							
	1995									2							
	1996									3							
STATOR MAT'L	RA, RR etc.										A						
ROTATING PARTS	1, 3, 4, 5, 8												3				
TYPICAL BASIC PUMP CODING	Cast Iron Flexishaft pump size 05 single stage. Mechanical seal, str thro E/C, Std F/shaft, Std duty conditions, Mk 0 rotor, Design 1, Natural rubber stator, Code 3 rotating parts	C	E	0	5	1	M	K	1	A	3						
MARKET VARIATIONS	'A' - America																
	'E' - Europe																
	'H' - Home																
	'C' - Bareshaft - Mono Australia only	C	E	0	5	1	M	K	1	A	3	/	A				
	'J' - Japan																

FULL PUMP CODING TO BE STAMPED ON PUMP NAMEPLATE

# Dismantling & Assembly Diagrams

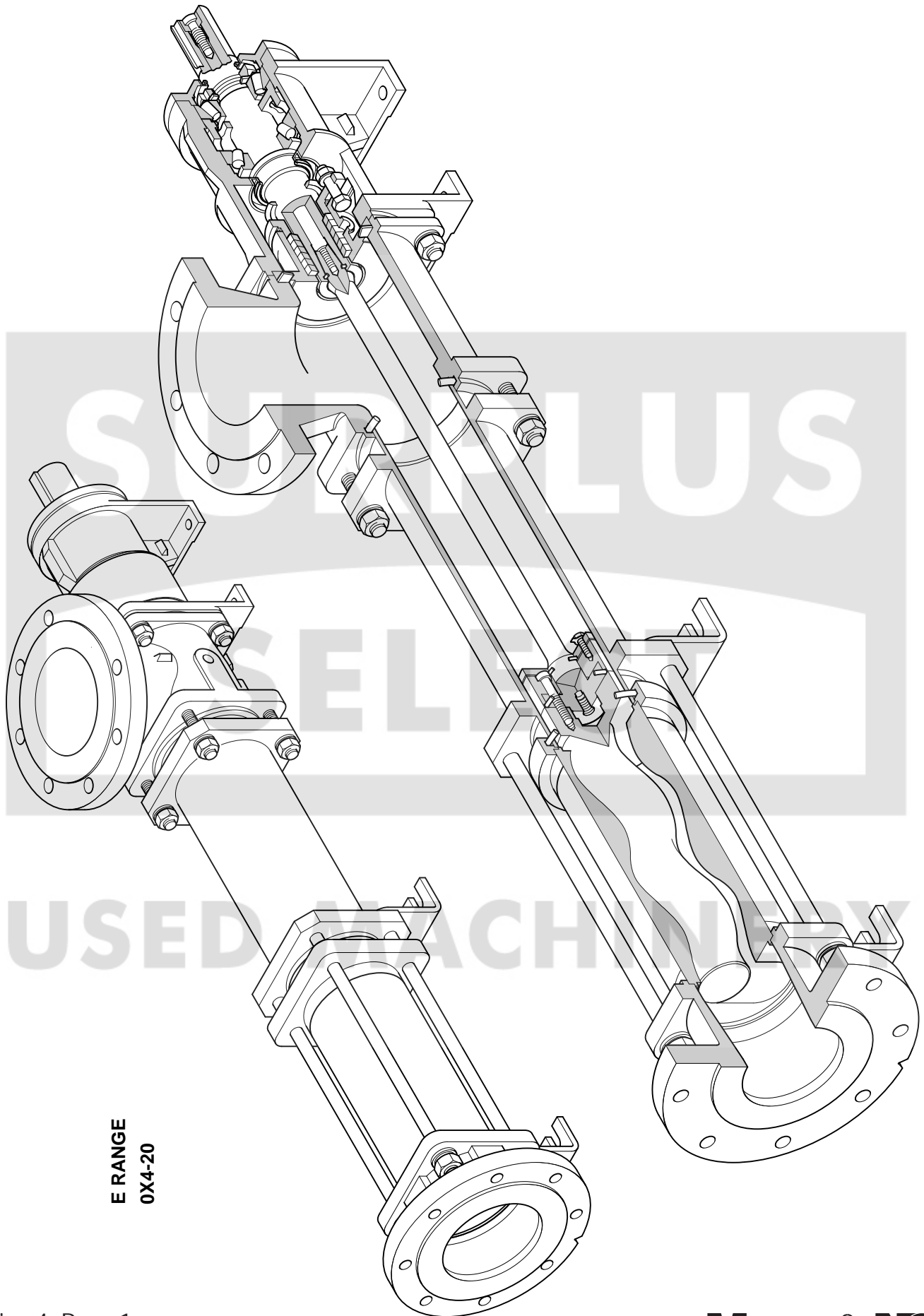

**E RANGE  
OX4-20**

# Dismantling & Assembly Diagrams

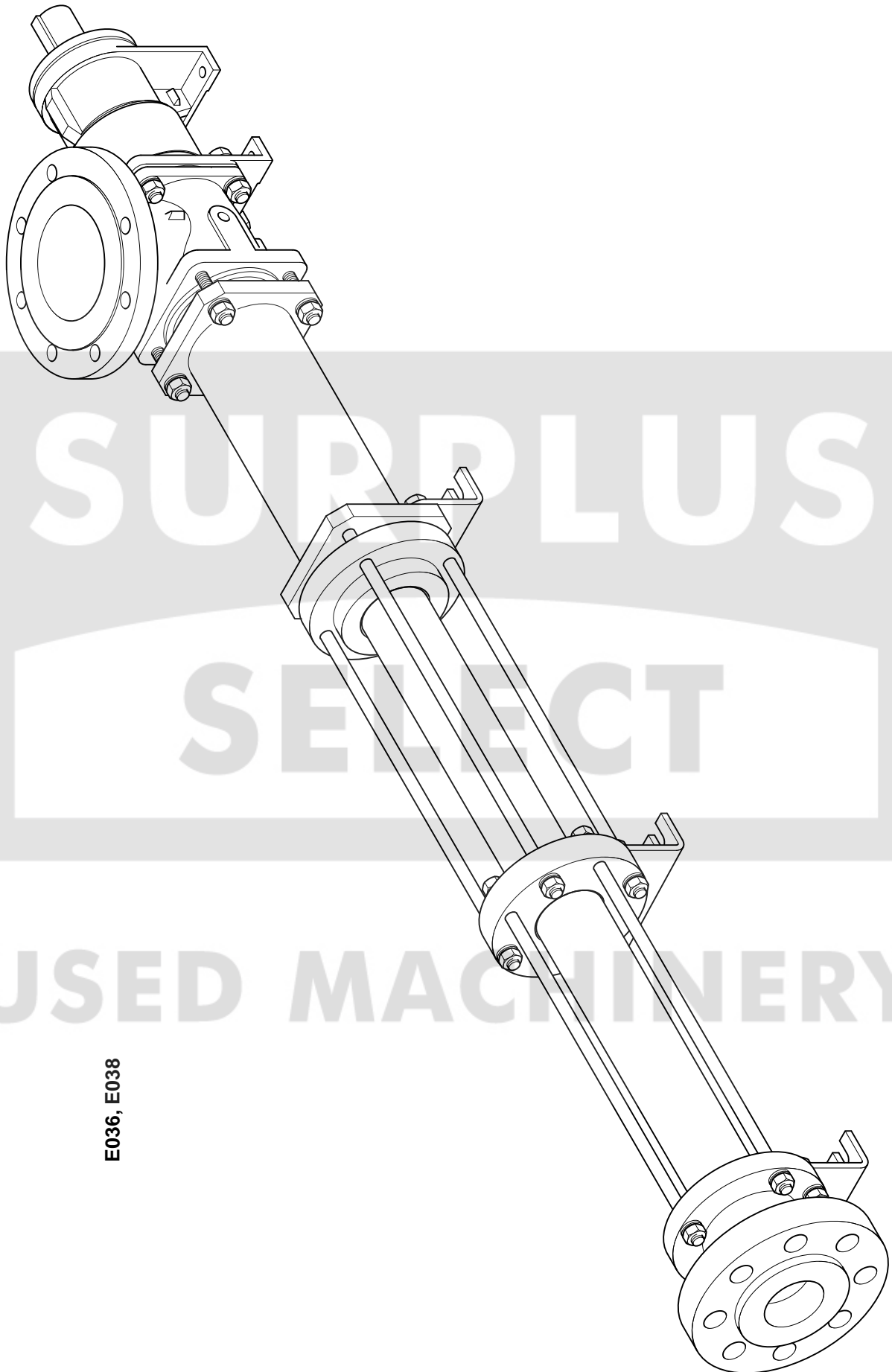

E036, E038

# Dismantling & Assembly Diagrams

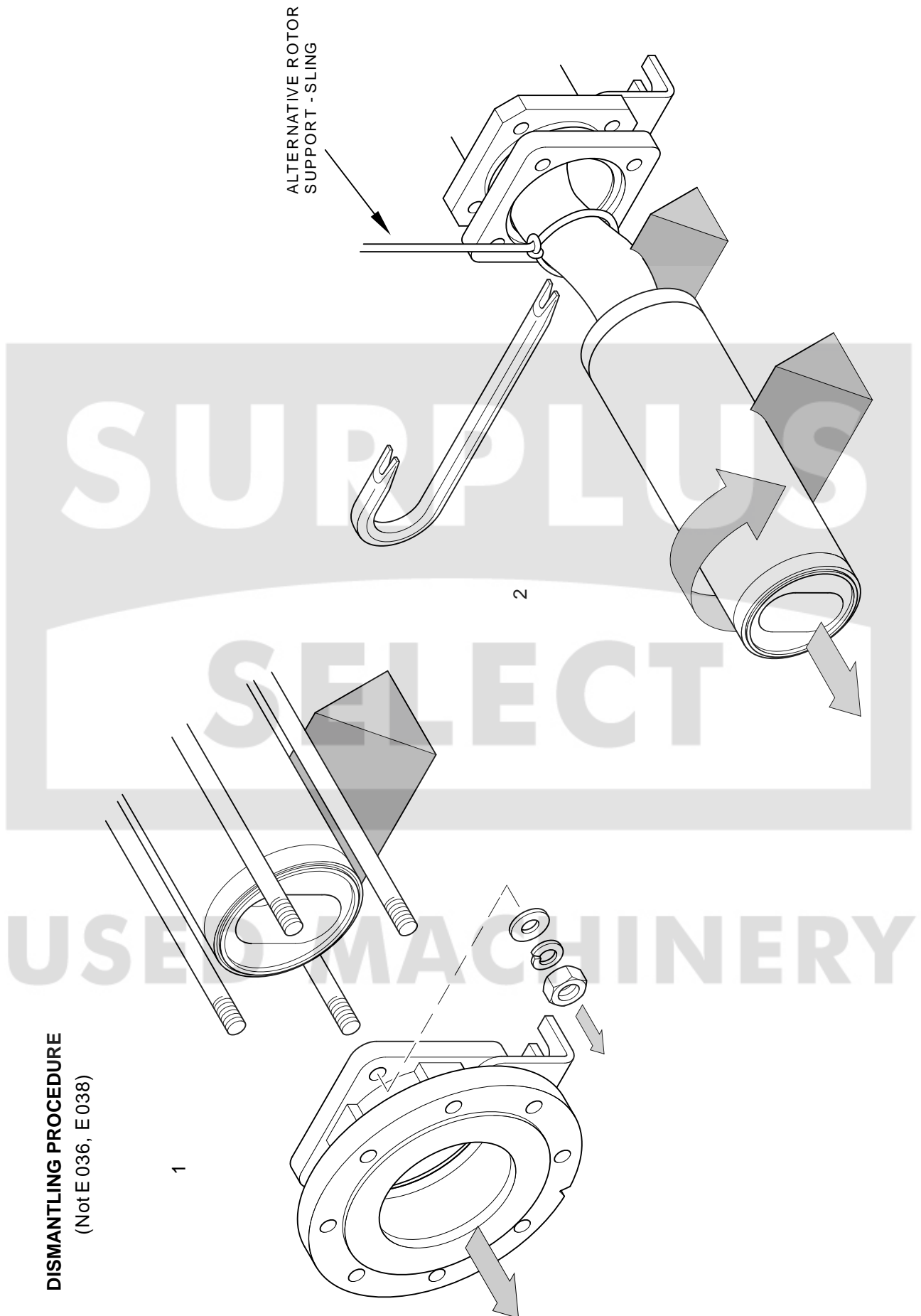

**DISMANTLING PROCEDURE**  
(Not E 036, E 038)

# Dismantling & Assembly Diagrams

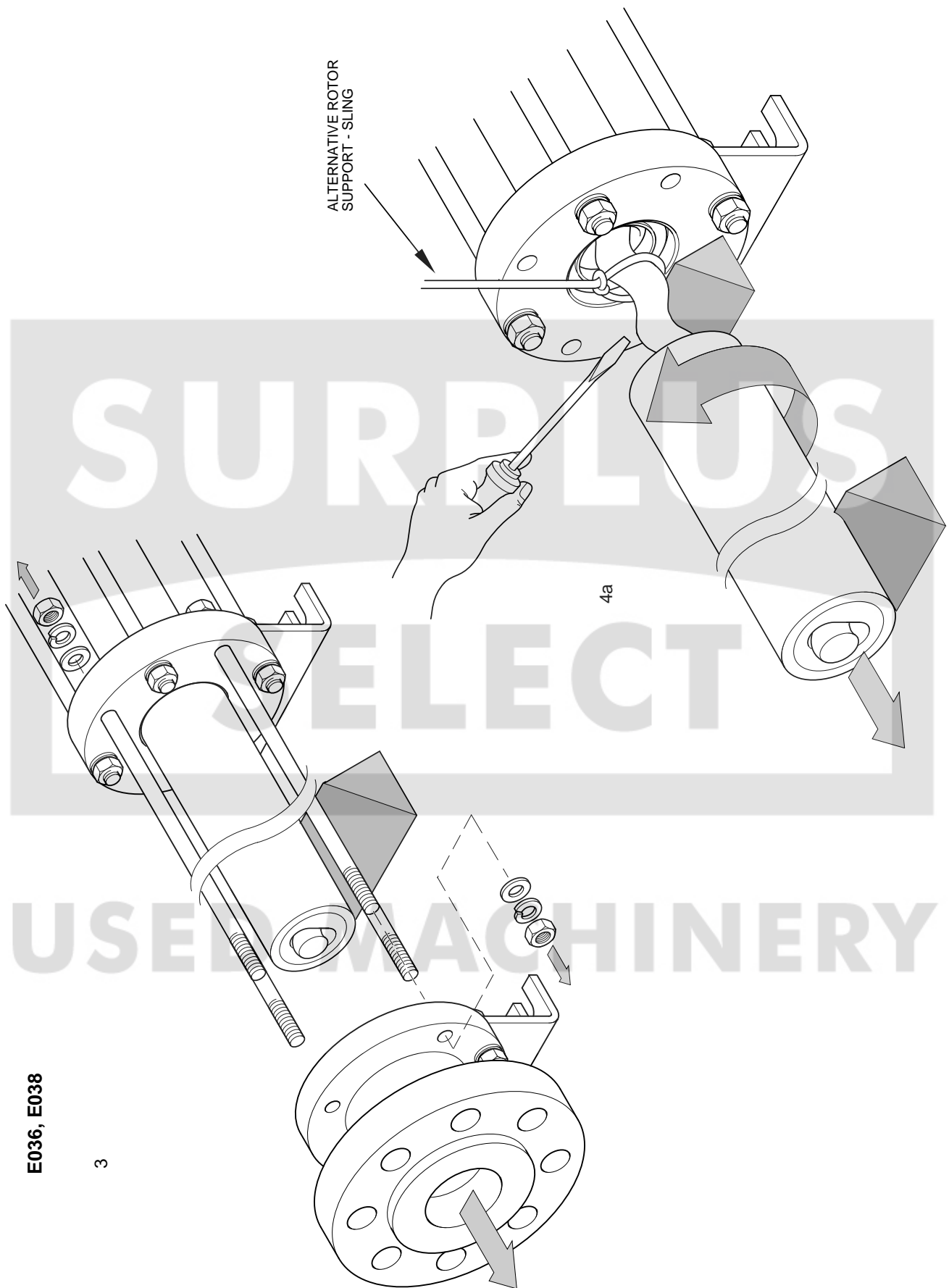

E036, E038

# Dismantling & Assembly Diagrams

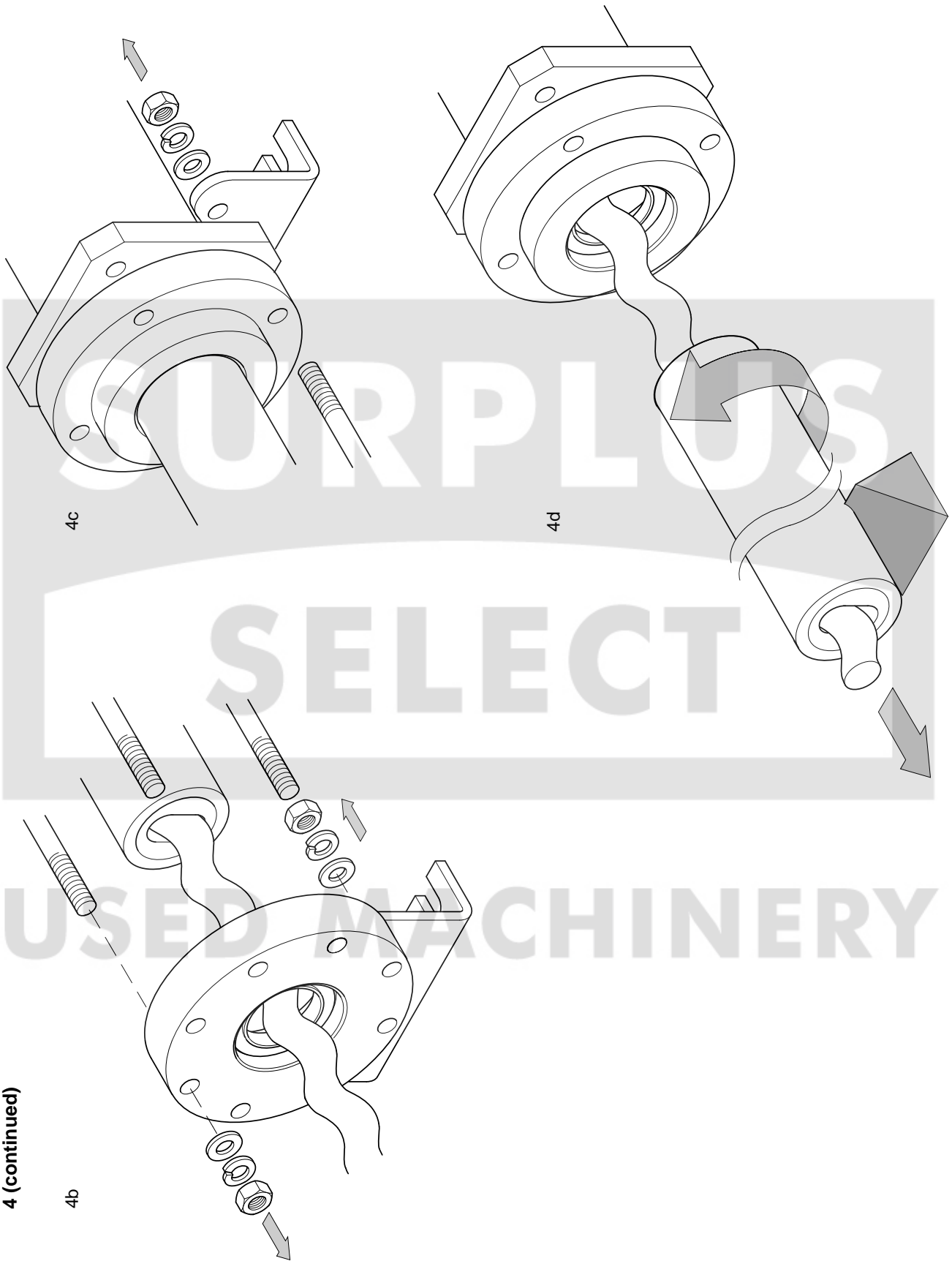

4 (continued)

# Dismantling & Assembly Diagrams

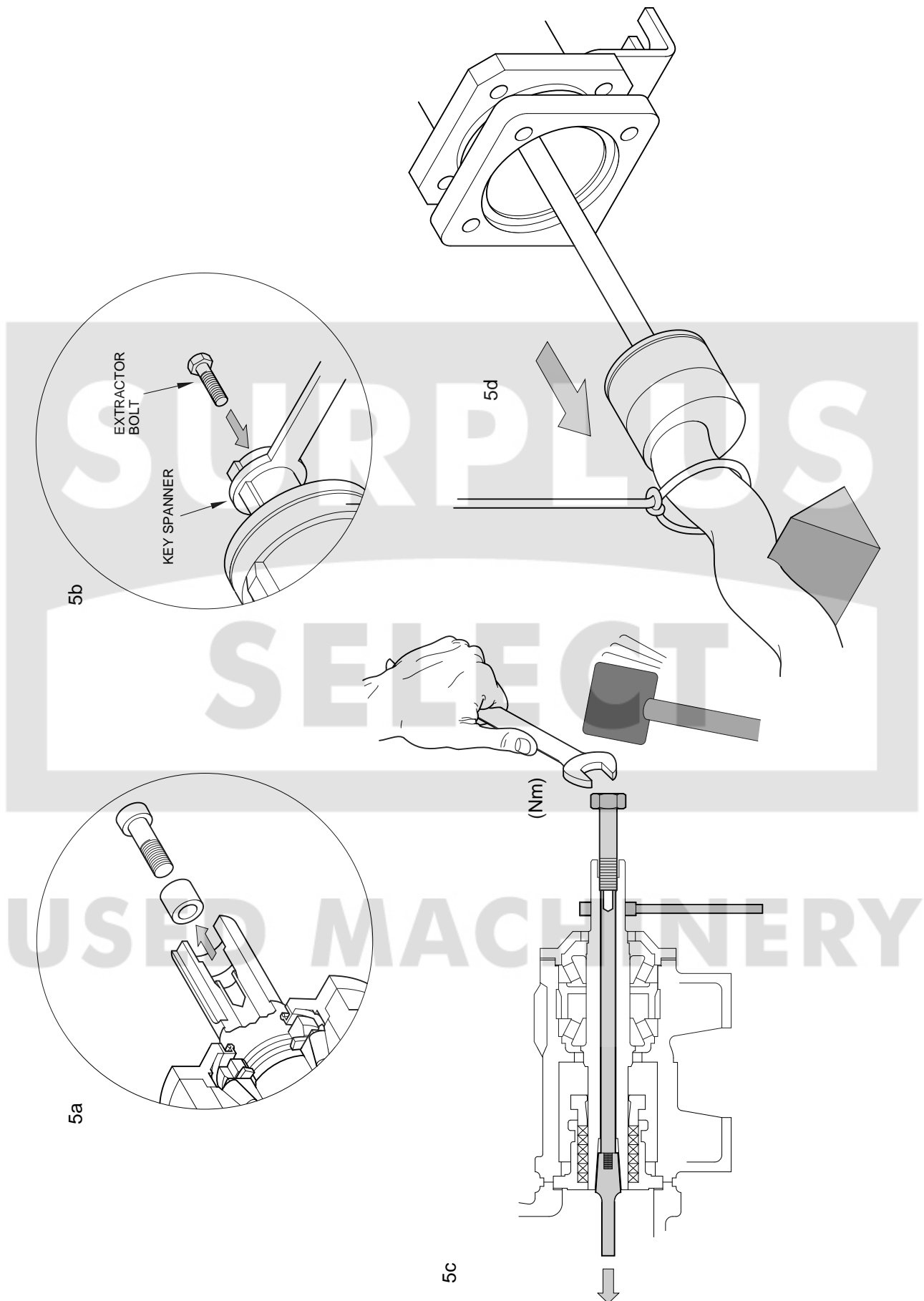

# Dismantling & Assembly Diagrams

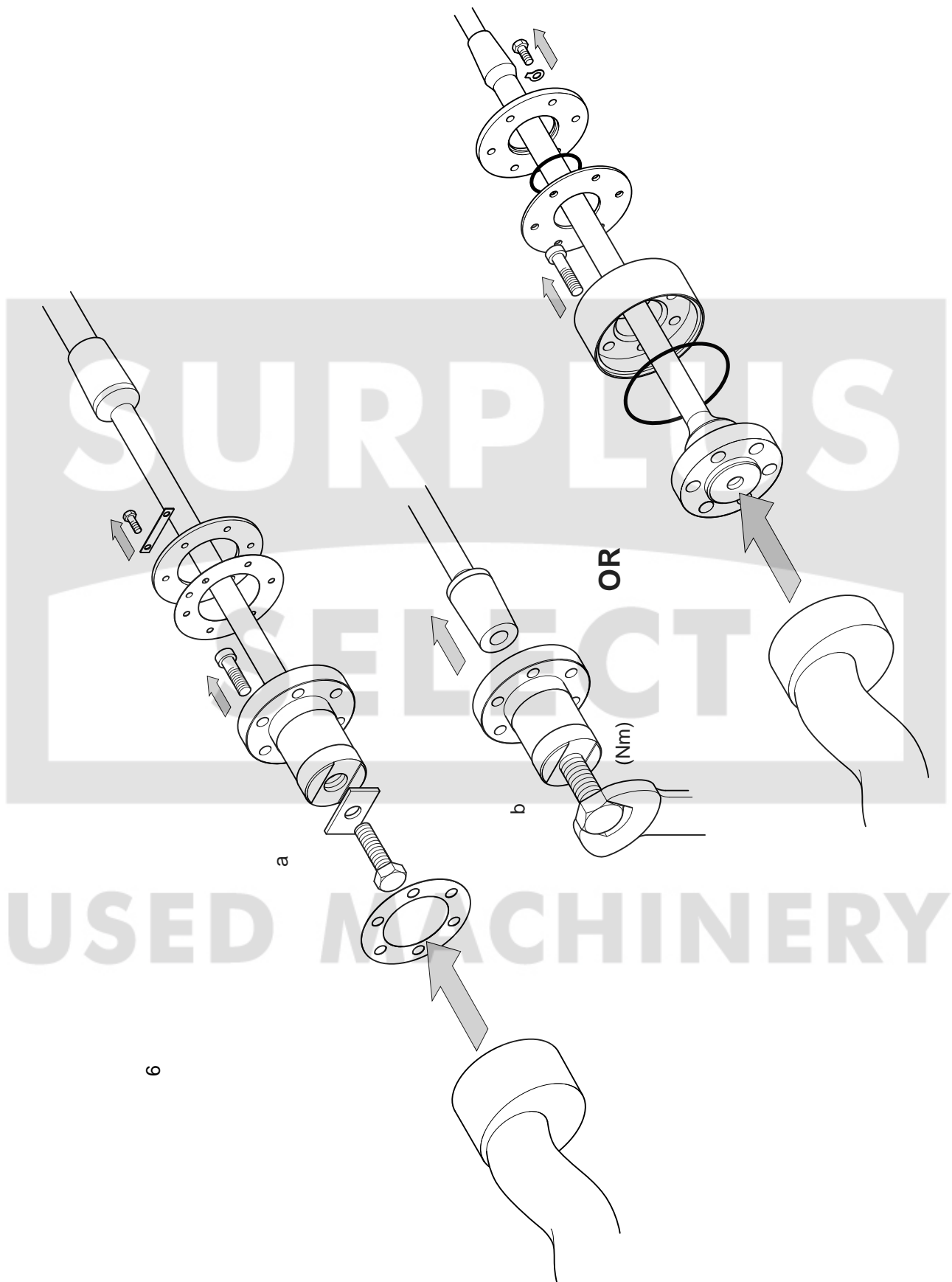

# Dismantling & Assembly Diagrams

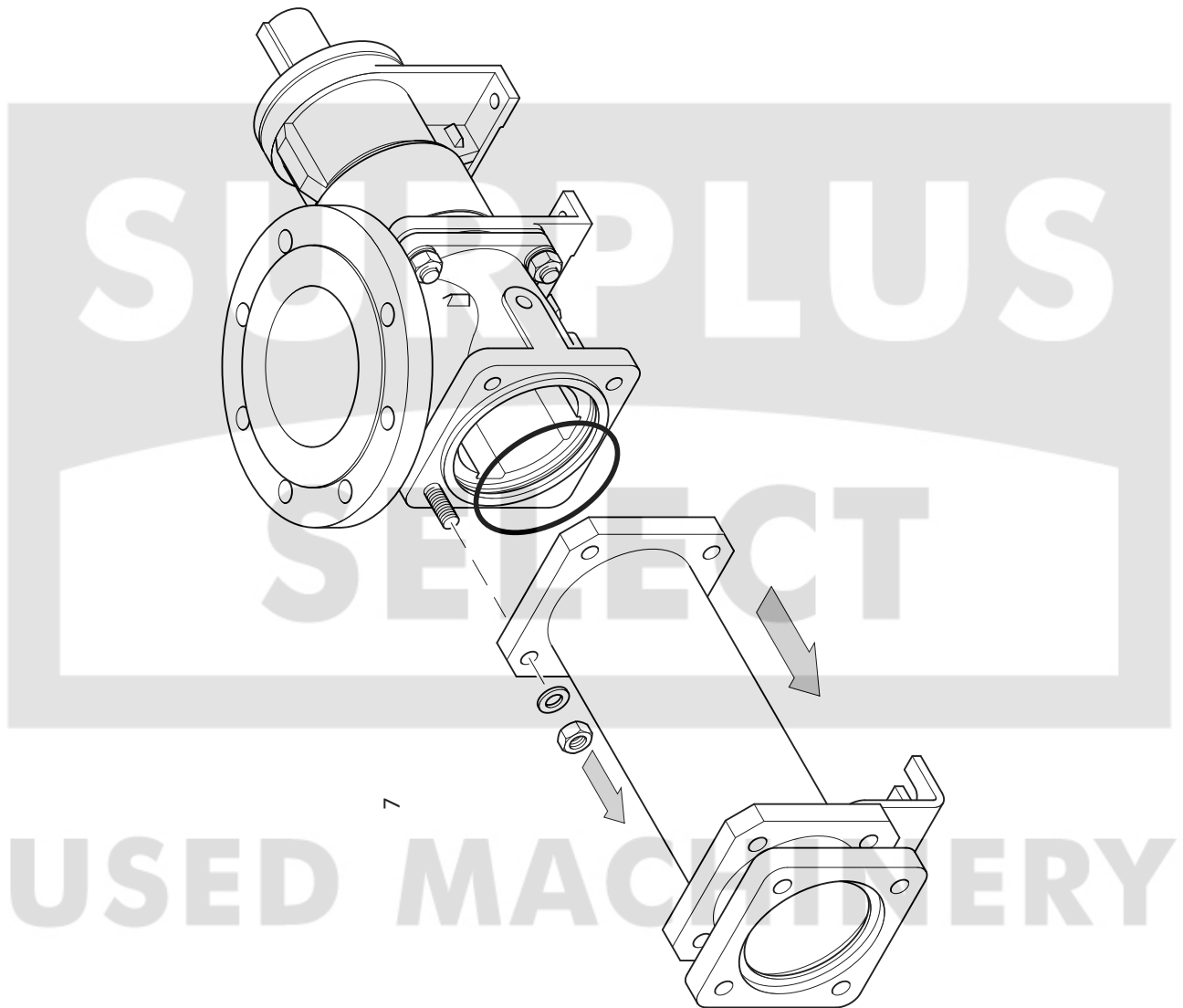

# Dismantling & Assembly Diagrams

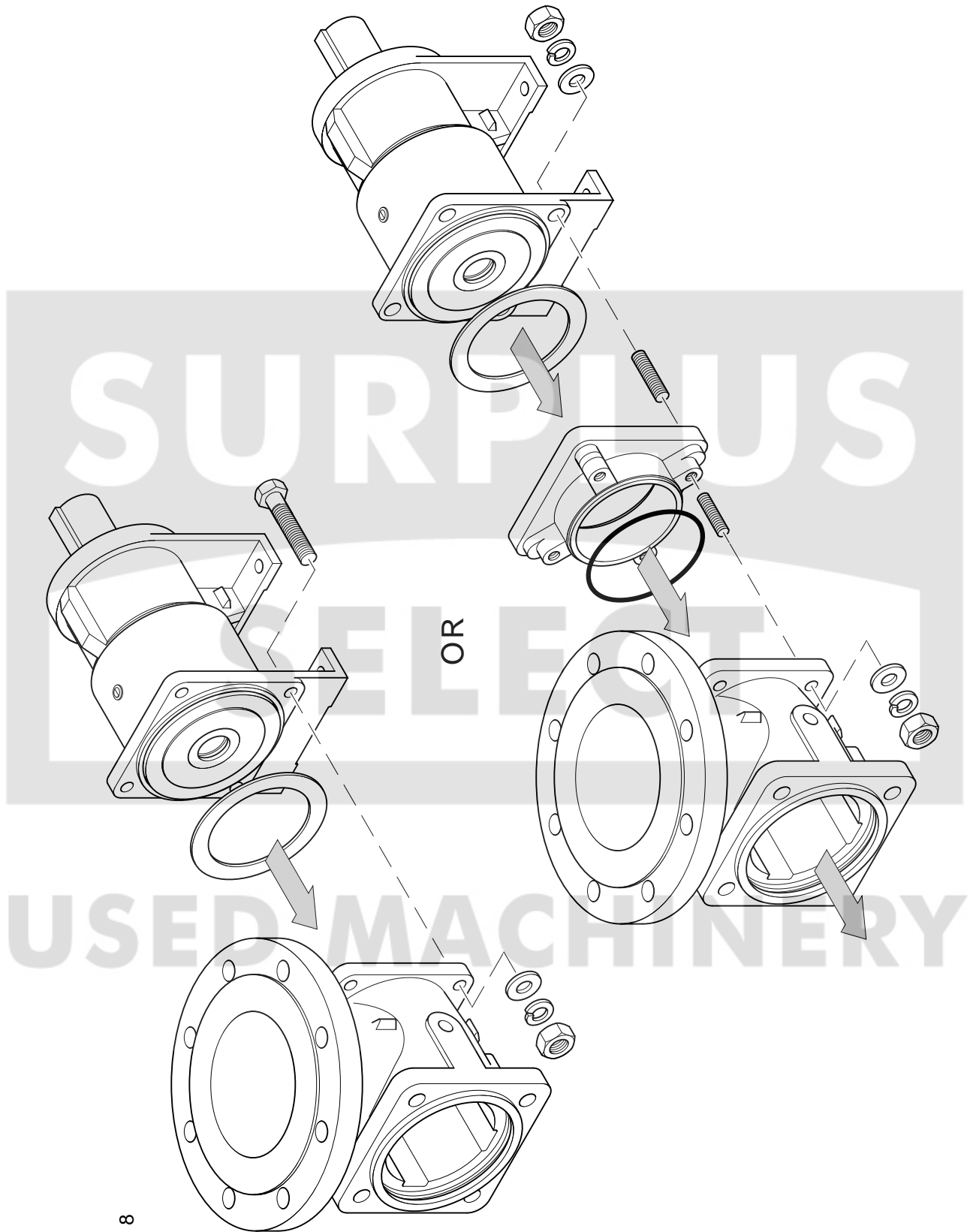

# Dismantling & Assembly Diagrams

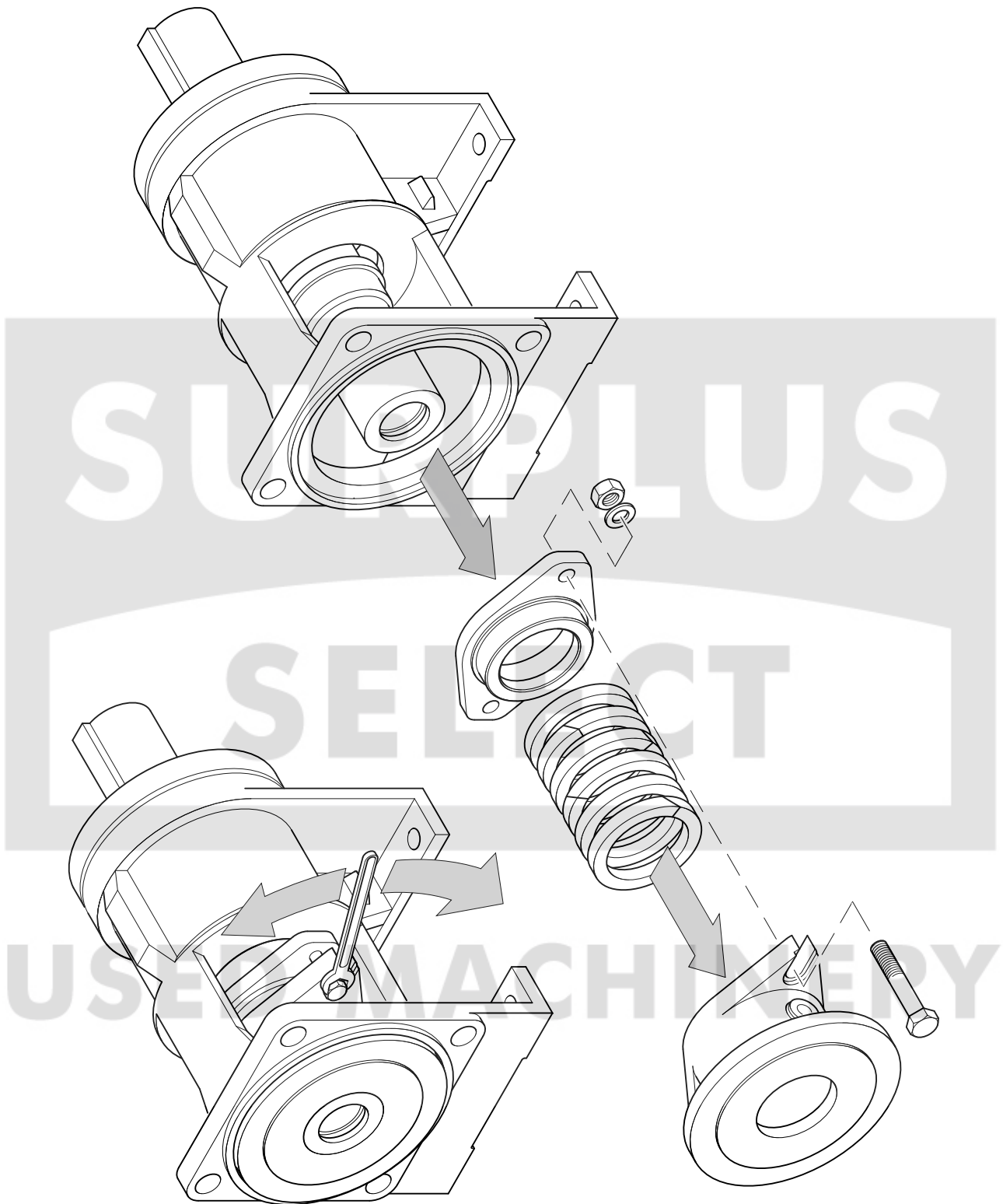

9

# Dismantling & Assembly Diagrams

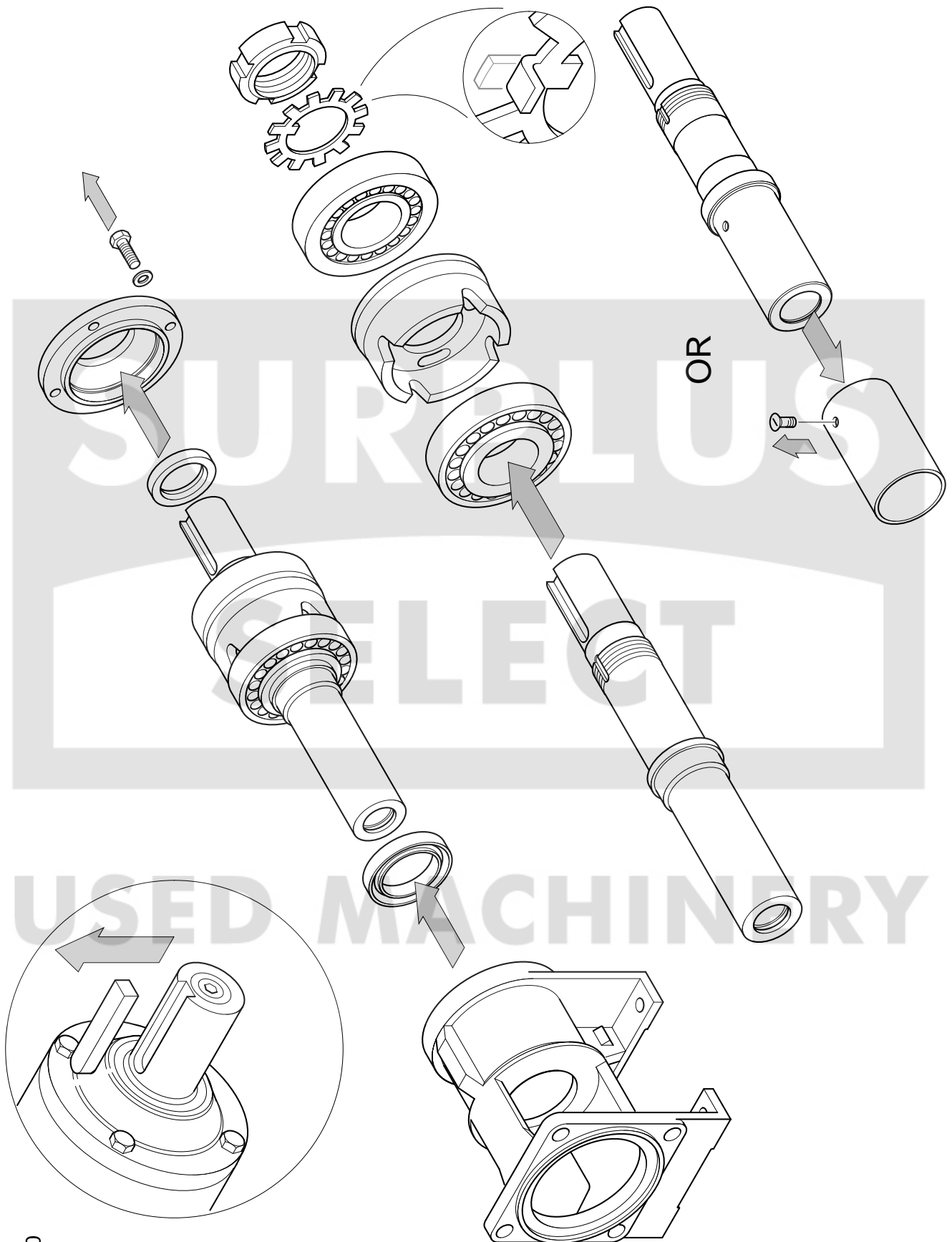

10

# Dismantling & Assembly Diagrams

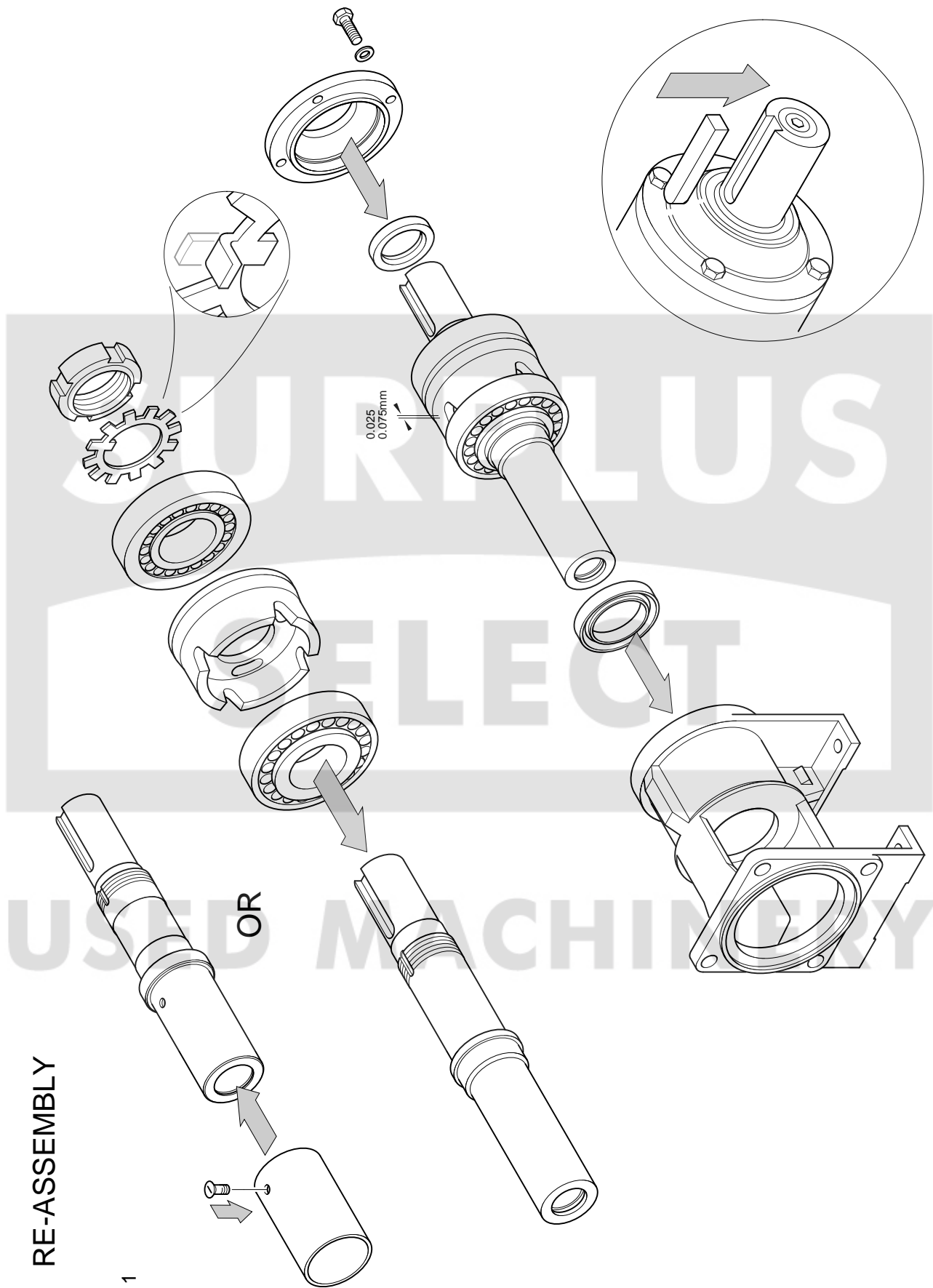

# Dismantling & Assembly Diagrams

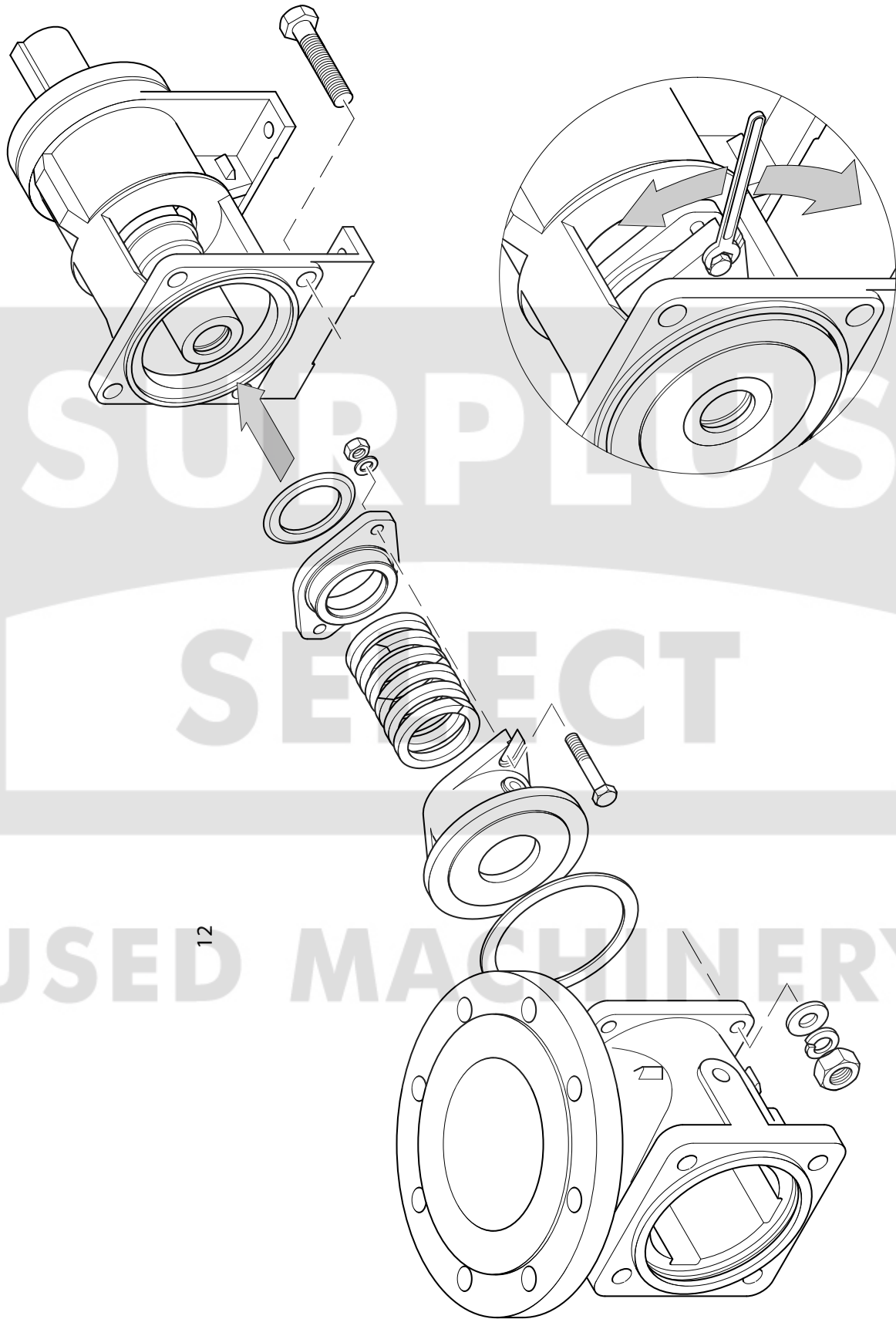

12

# Dismantling & Assembly Diagrams

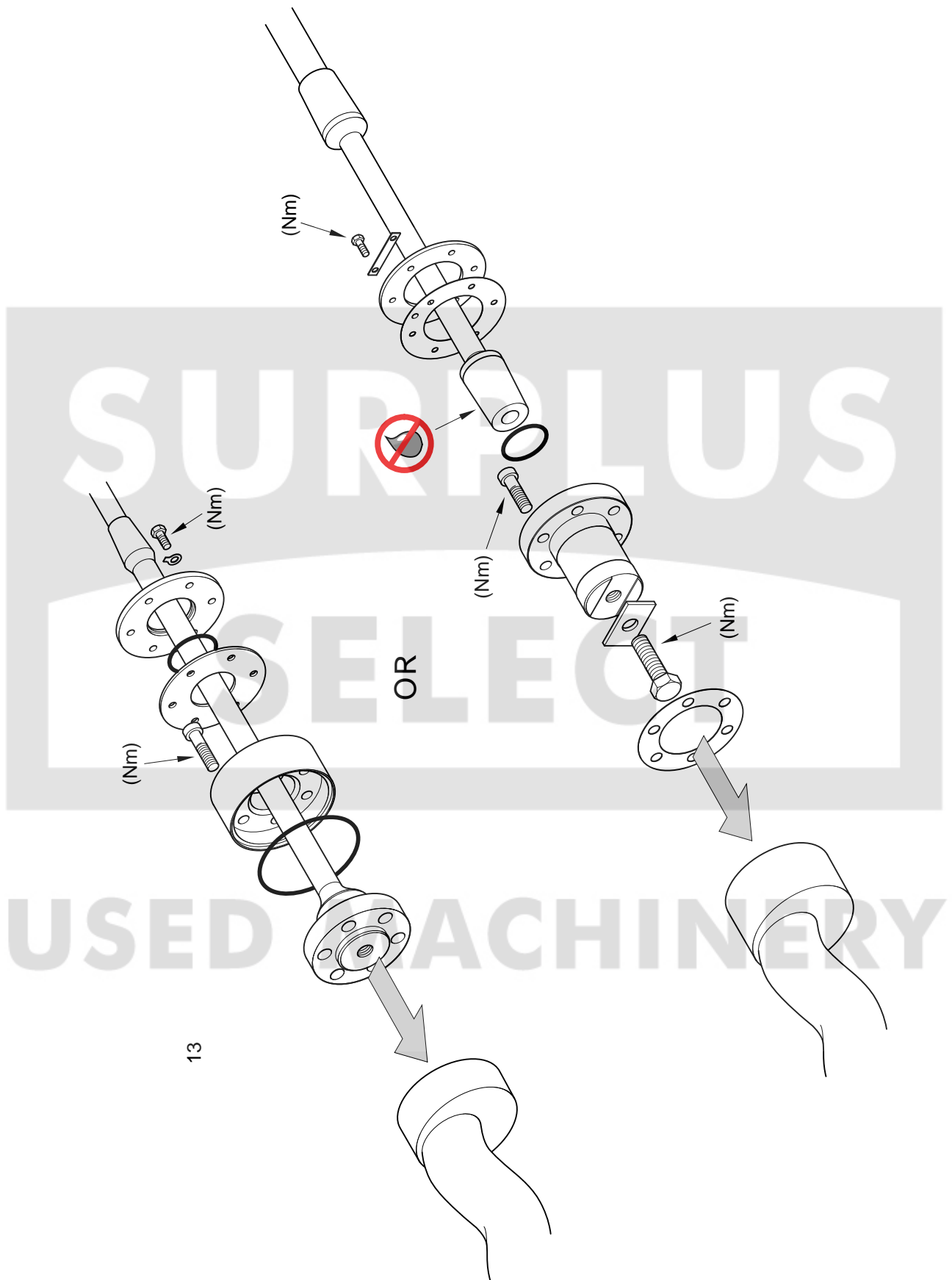

13

# Dismantling & Assembly Diagrams

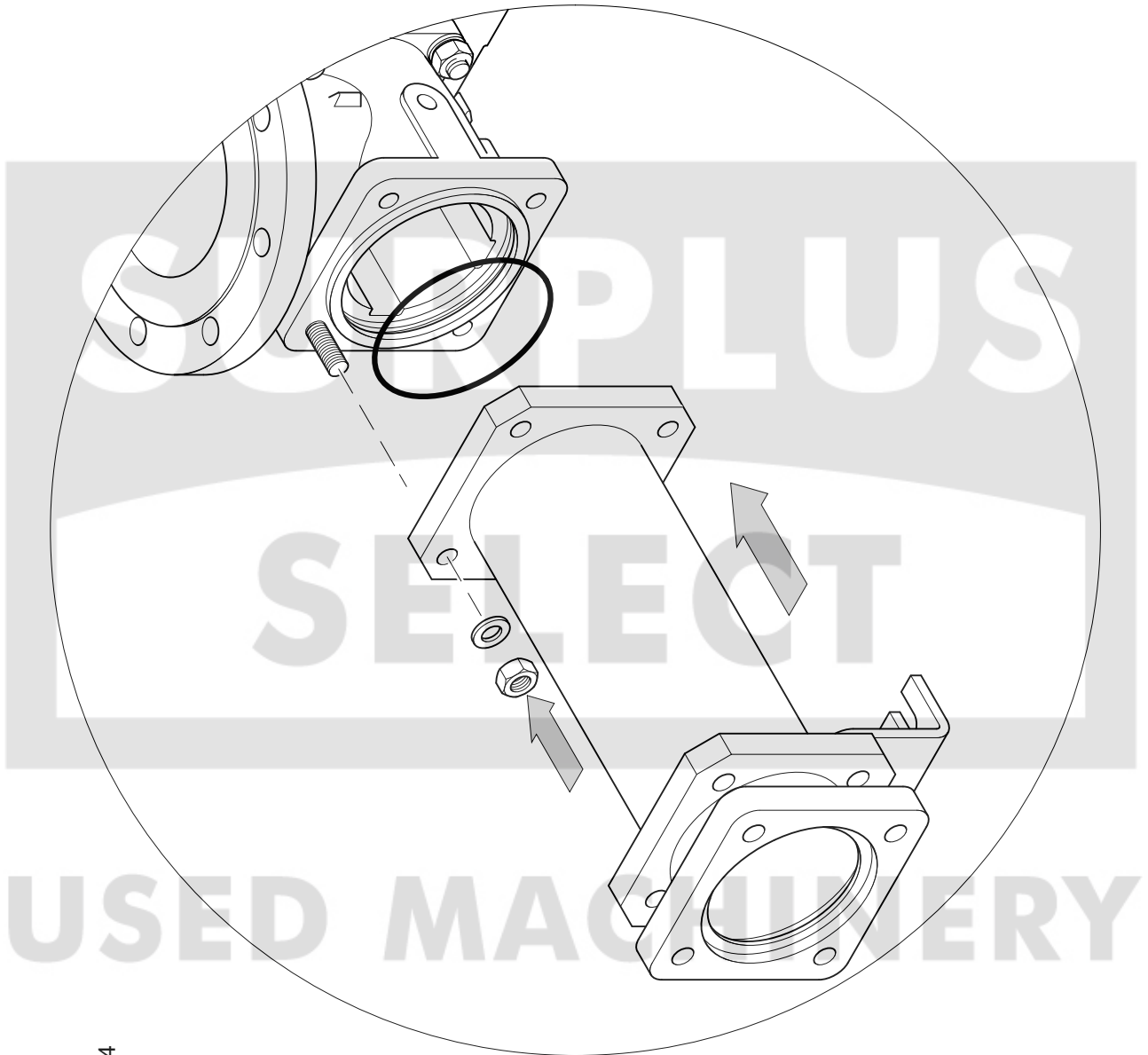

14

# Dismantling & Assembly Diagrams

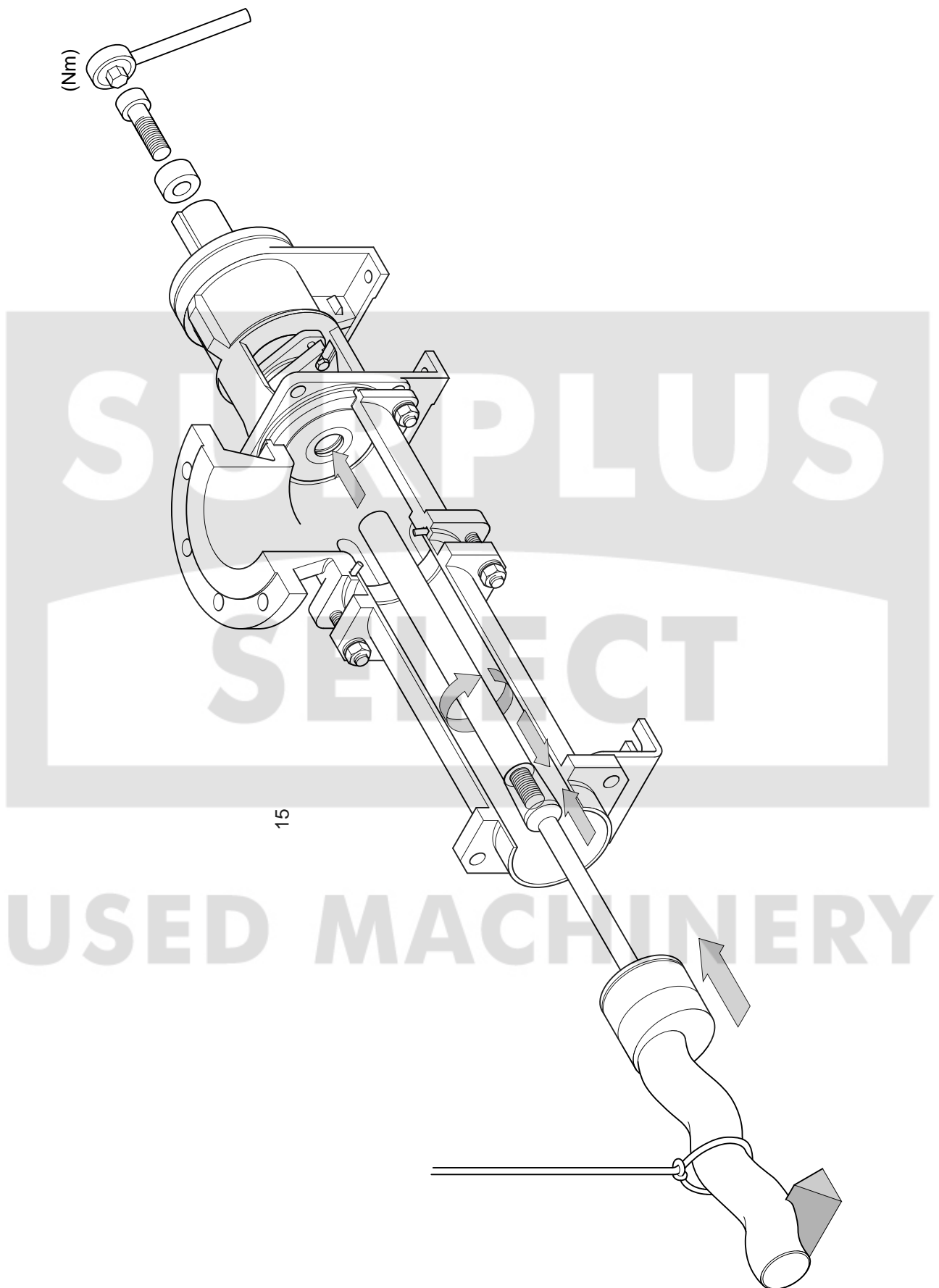

# Dismantling & Assembly Diagrams

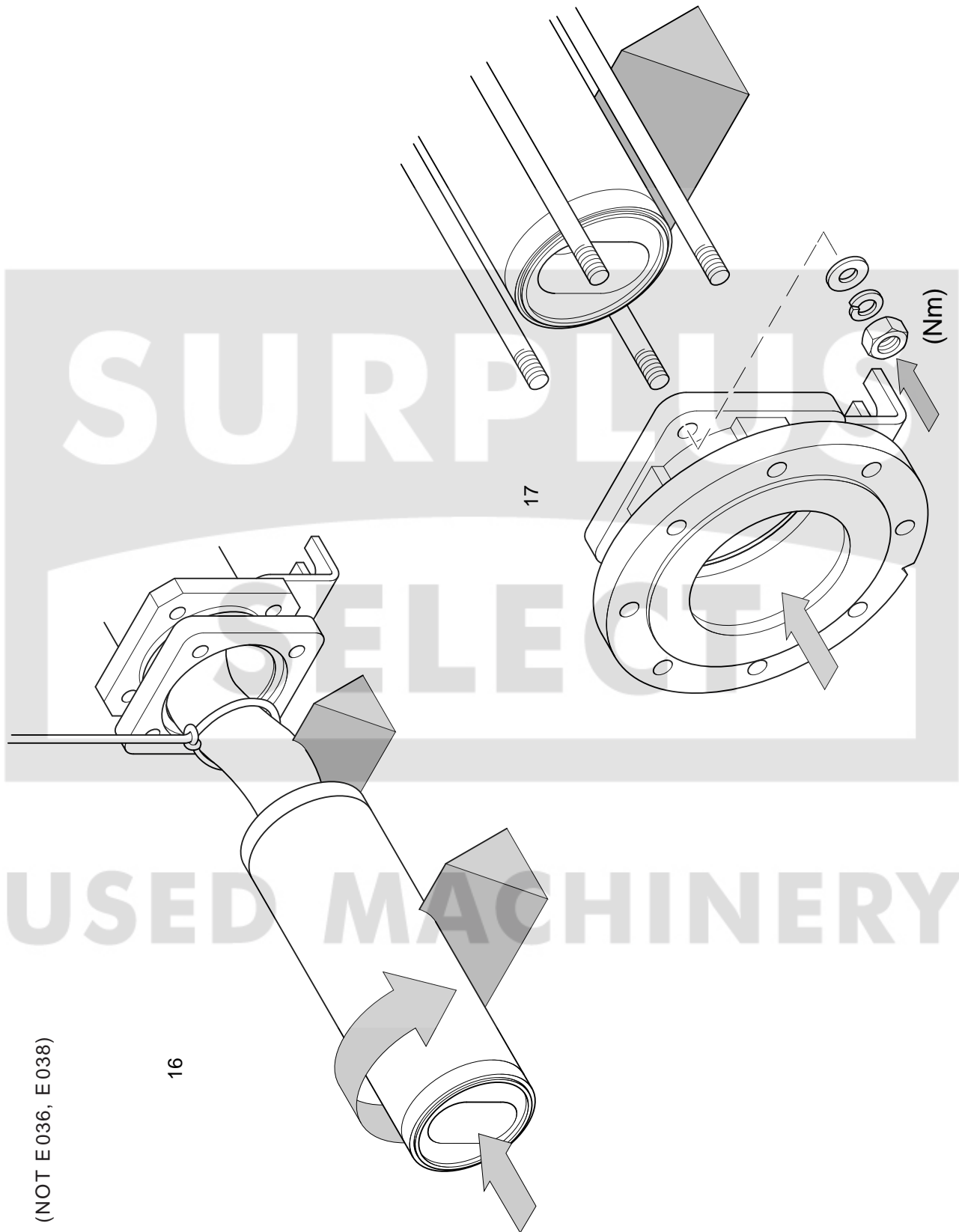

(NOT E036, E038)

16

17

# Dismantling & Assembly Diagrams

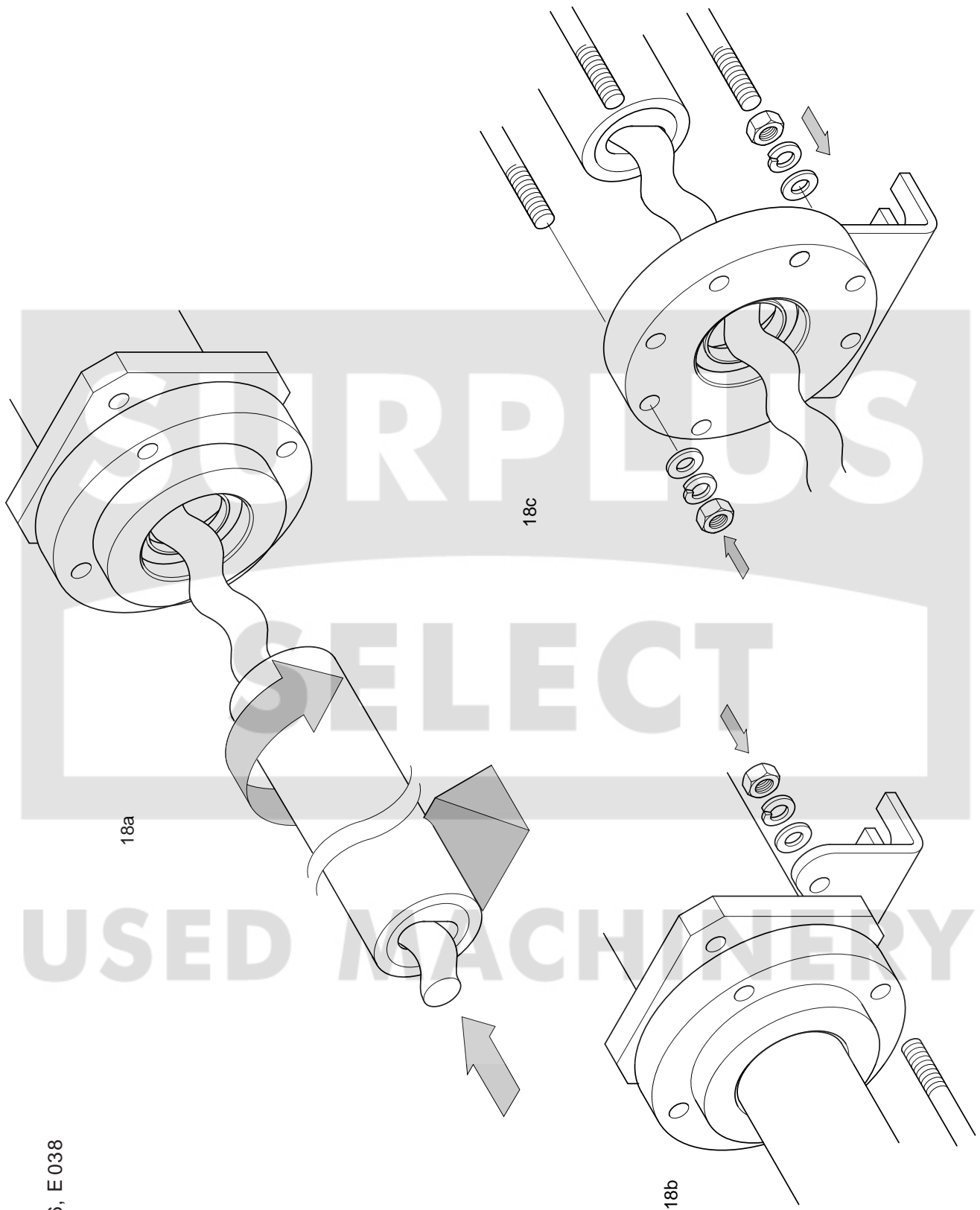

E 036, E 038

# Dismantling & Assembly Diagrams

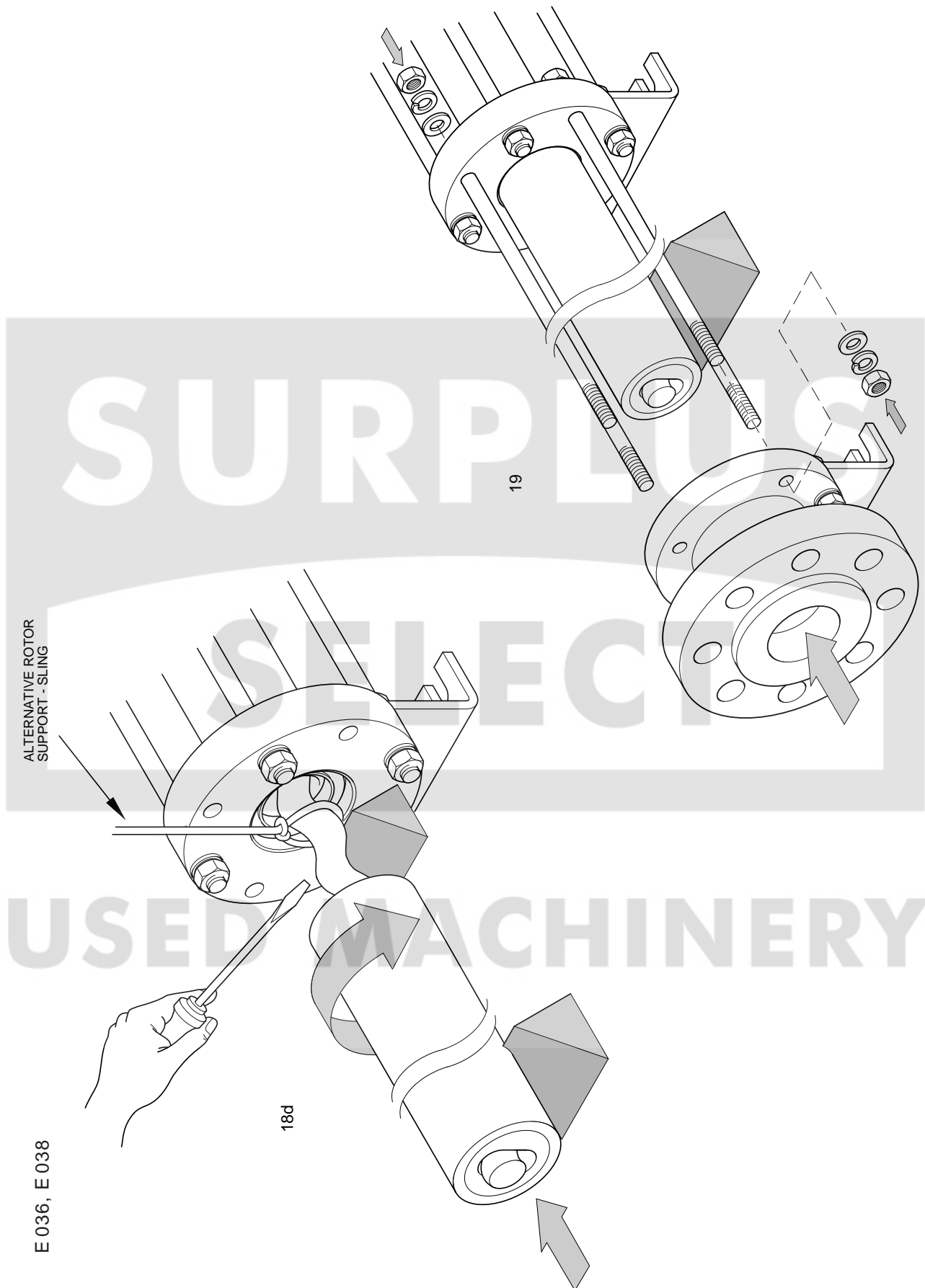

ALTERNATIVE ROTOR  
SUPPORT - SLING

E 036, E 038

# Exploded Views

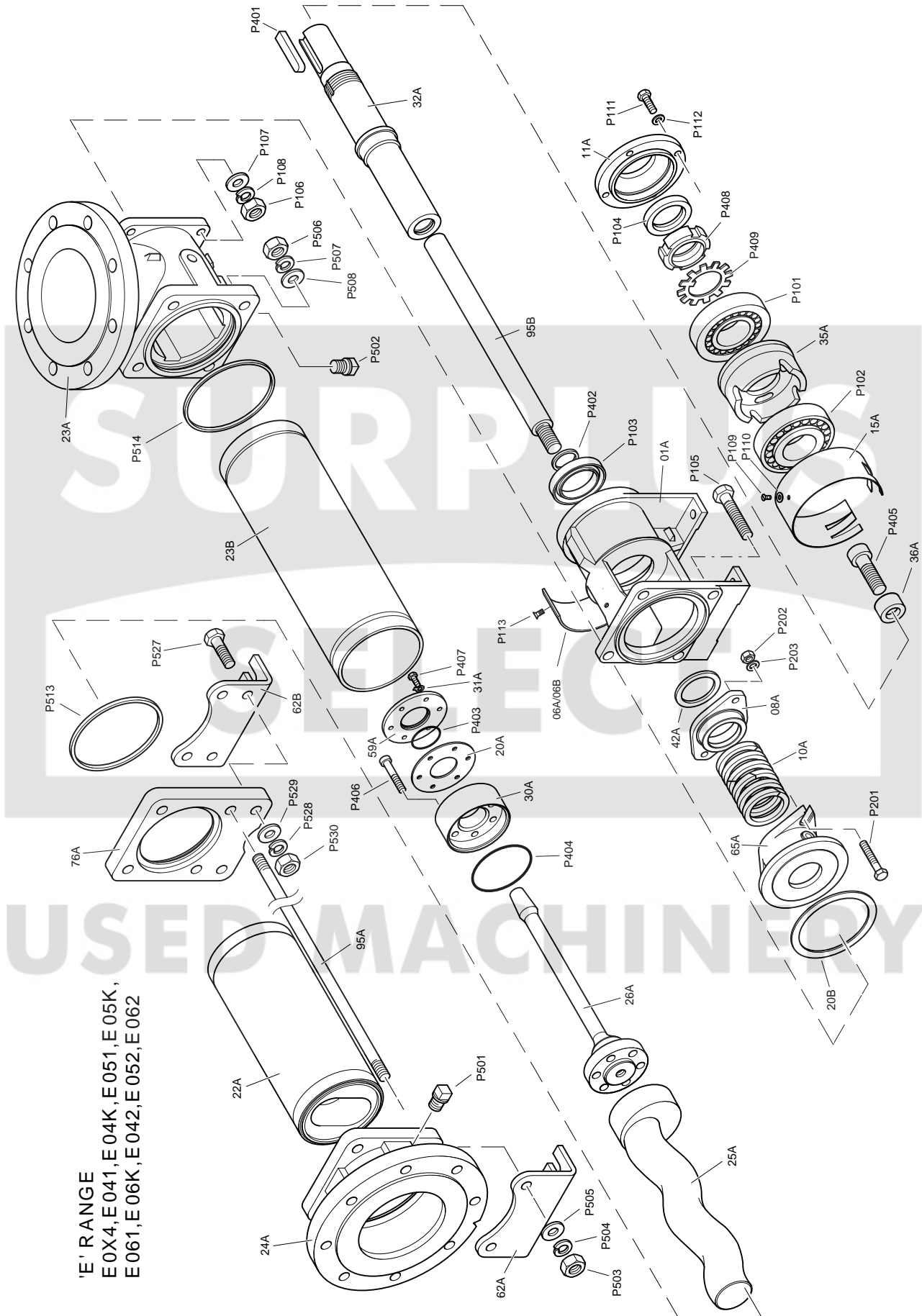

'E' RANGE  
 E0X4, E041, E04K, E051, E05K,  
 E061, E06K, E042, E052, E062

# Exploded Views

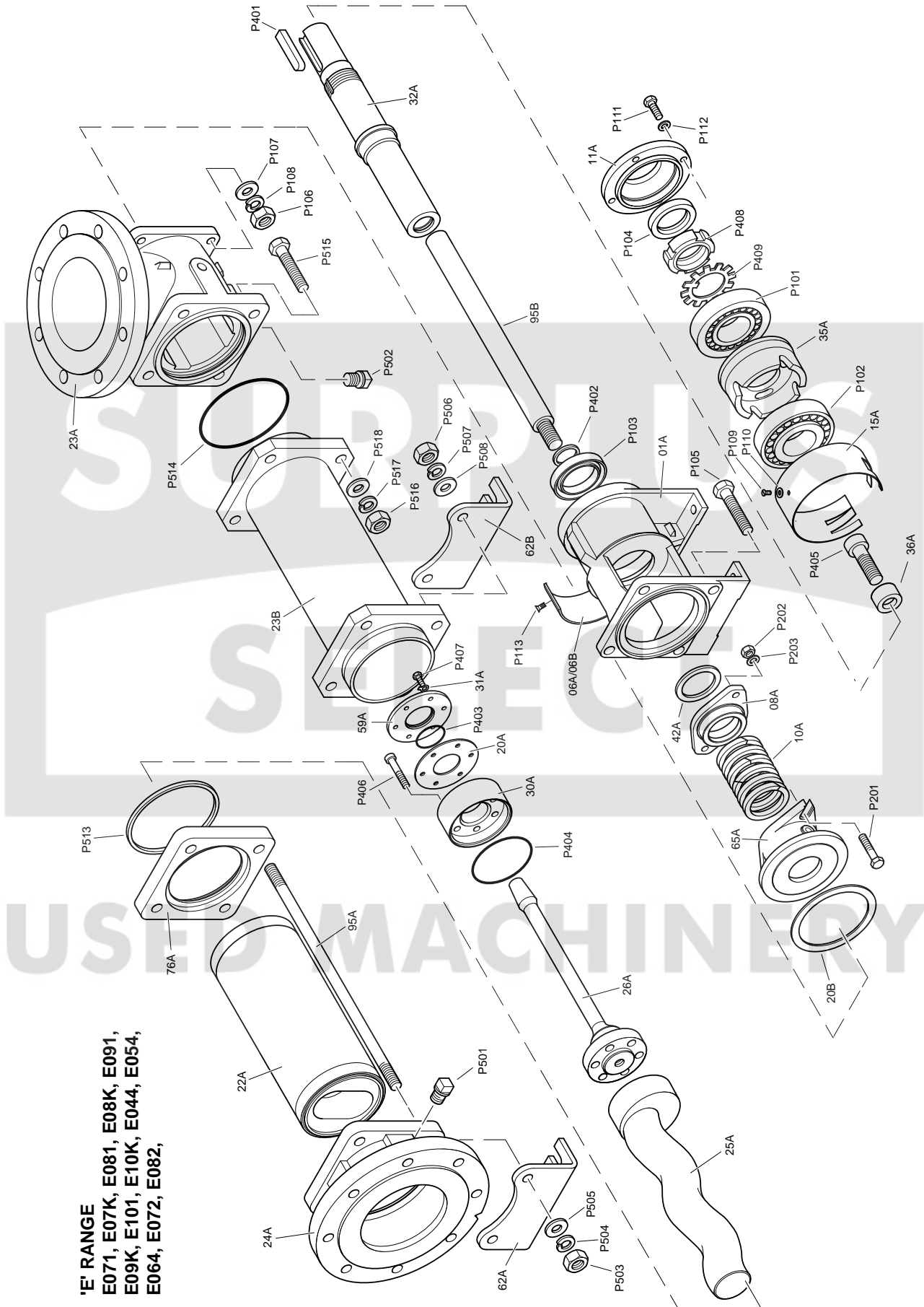

**'E' RANGE**  
**E071, E07K, E081, E08K, E091,**  
**E09K, E101, E10K, E044, E054,**  
**E064, E072, E082,**

# Exploded Views

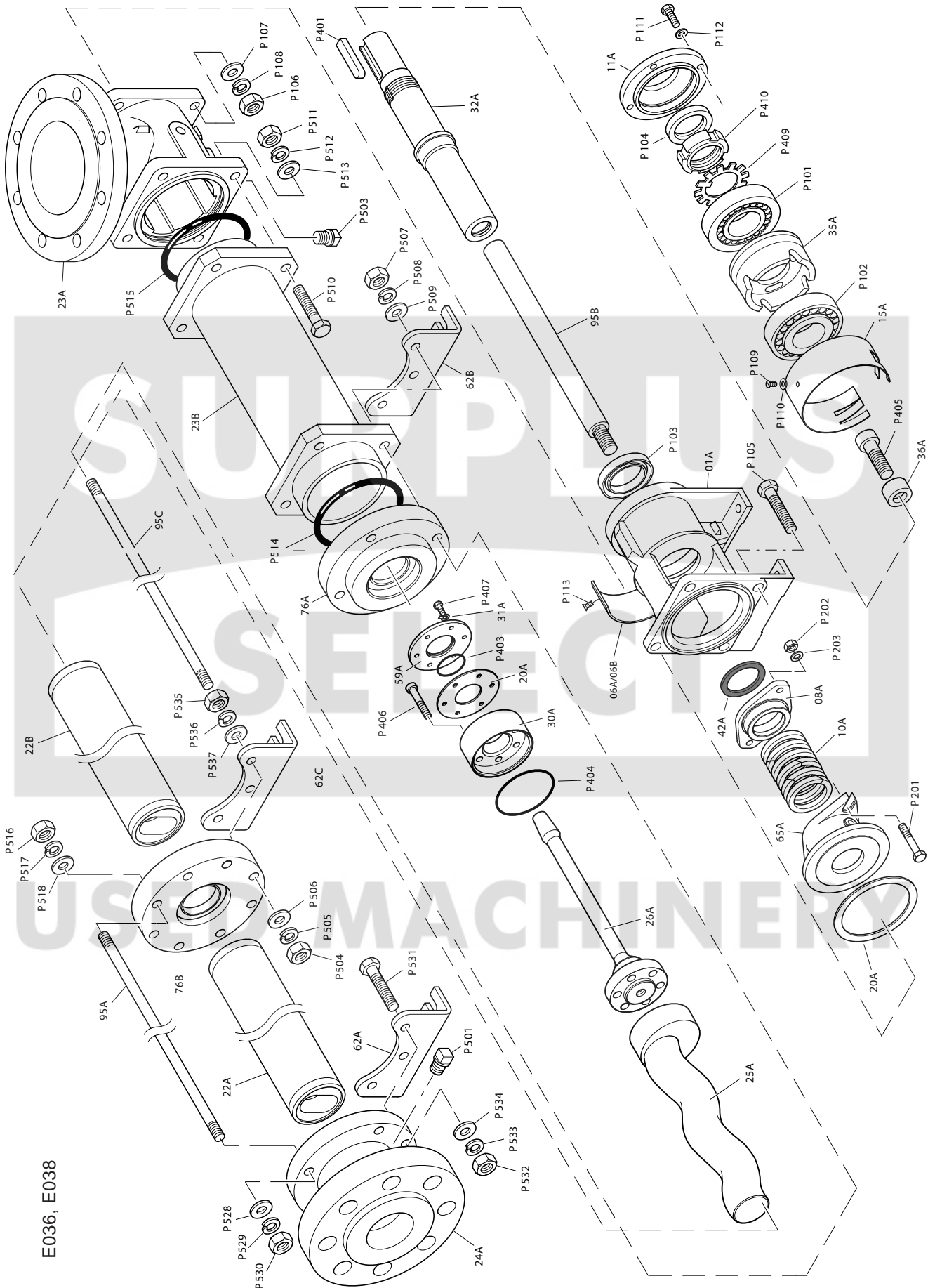

E036, E038

# Setting Length - Mechanical Seal

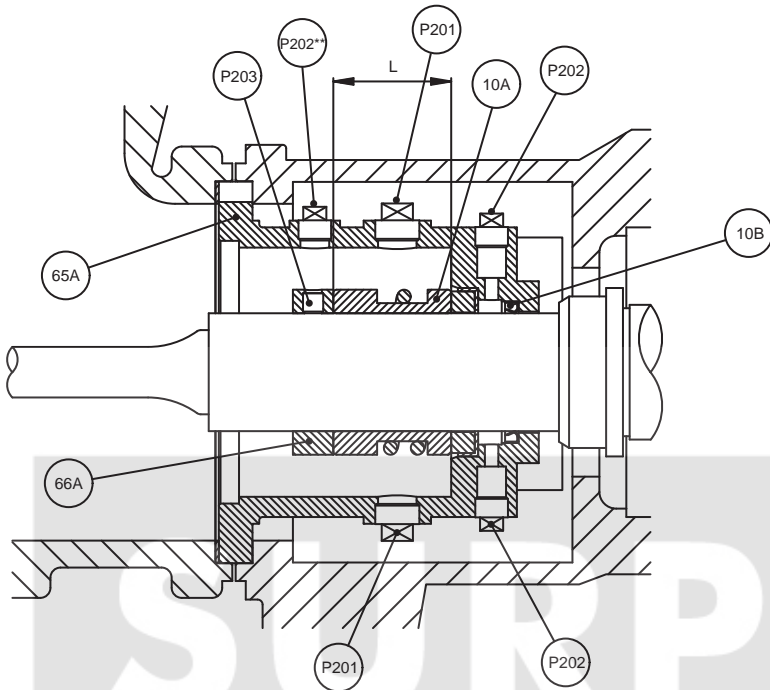

Drawing Identification Number	Description
P201	1/4" NPSI Taper Plug
P202	1/8" NPSI Taper Plug
P203	Grub Screw
10A	Mechanical Seal
10B	Lipseal (Optional)
65A	Seal Housing
66A	Abutment Ring

Pump Models	Seal Housing	Shaft Diameter (mm)	Setting Length L Crane 2100* (mm)
E021 E022 E024 E03K E031 E032 E0XK E0X1	E012	32	35.5
E026 E028 E034 E0X2 E04K E041	E041	32	35.5
E0X4 E042 E05K E051 E036 E038	E051	35	34.5
E044 E048L E052 E06K E061	E061	45	37
E048 E054 E062 E07K E071 E08K E081	E081	55	37.5
E064 E072 E082 E09K E091 E10K E101	E101	65	40.5
E066 E068 E074 E084 E092 E102, E103 E12K E121	E121	85	47.5

\* For seals other than the Crane 2100 please refer to the manufacturer's instructions.

\*\* Not on Seal Housing size E012

# Exploded Views - Mechanical Seal

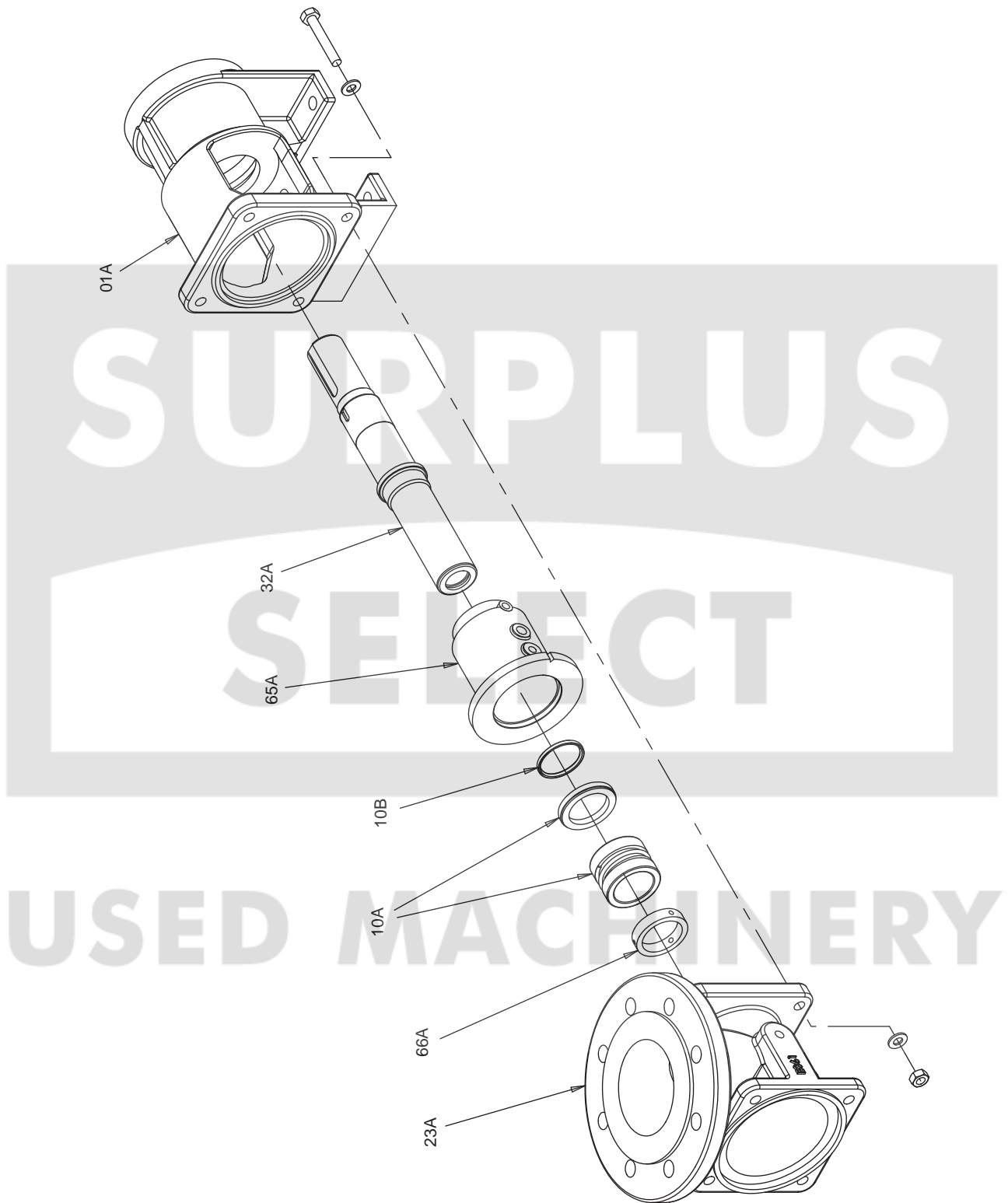

# Exploded Views

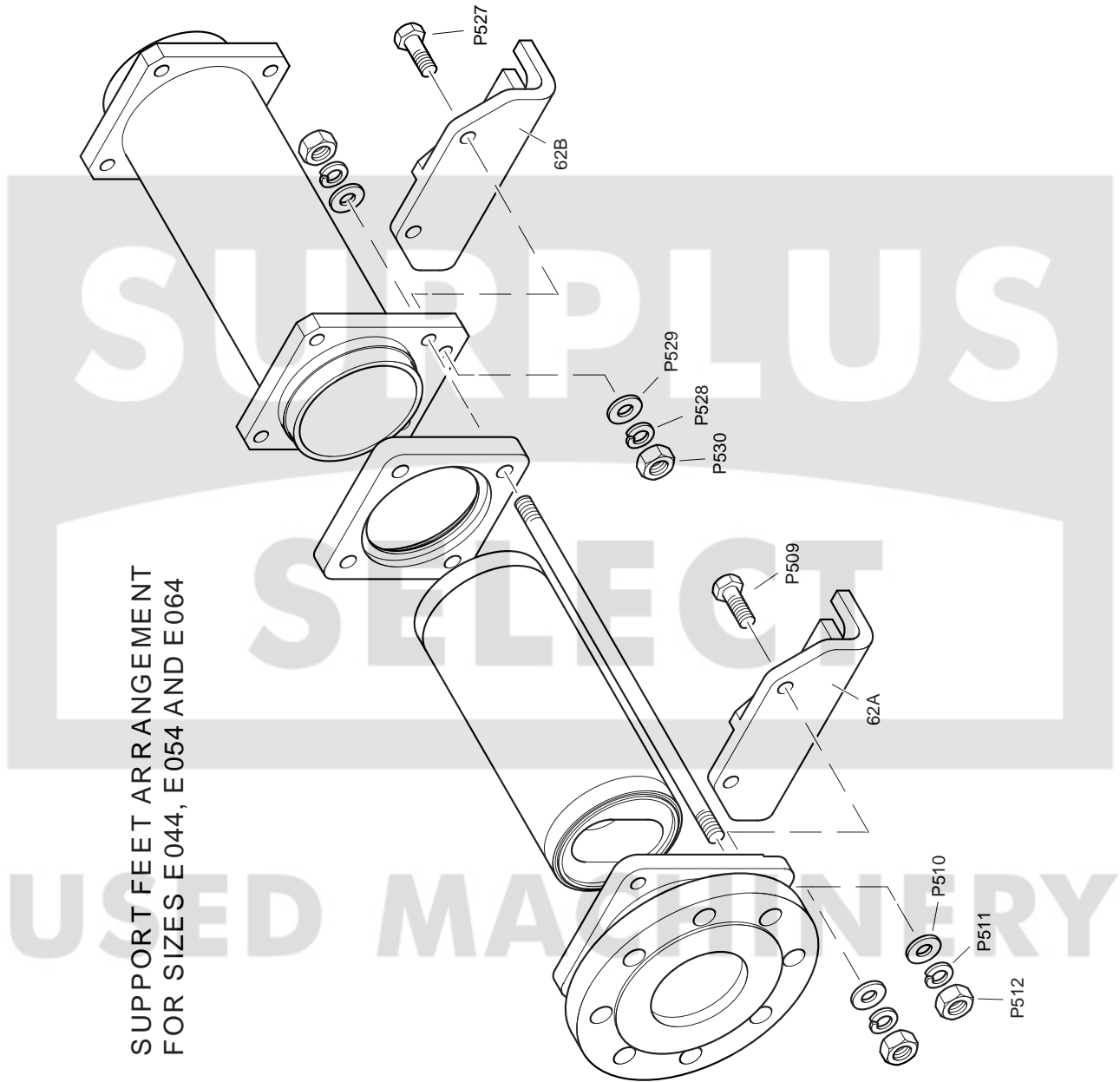

# Exploded Views

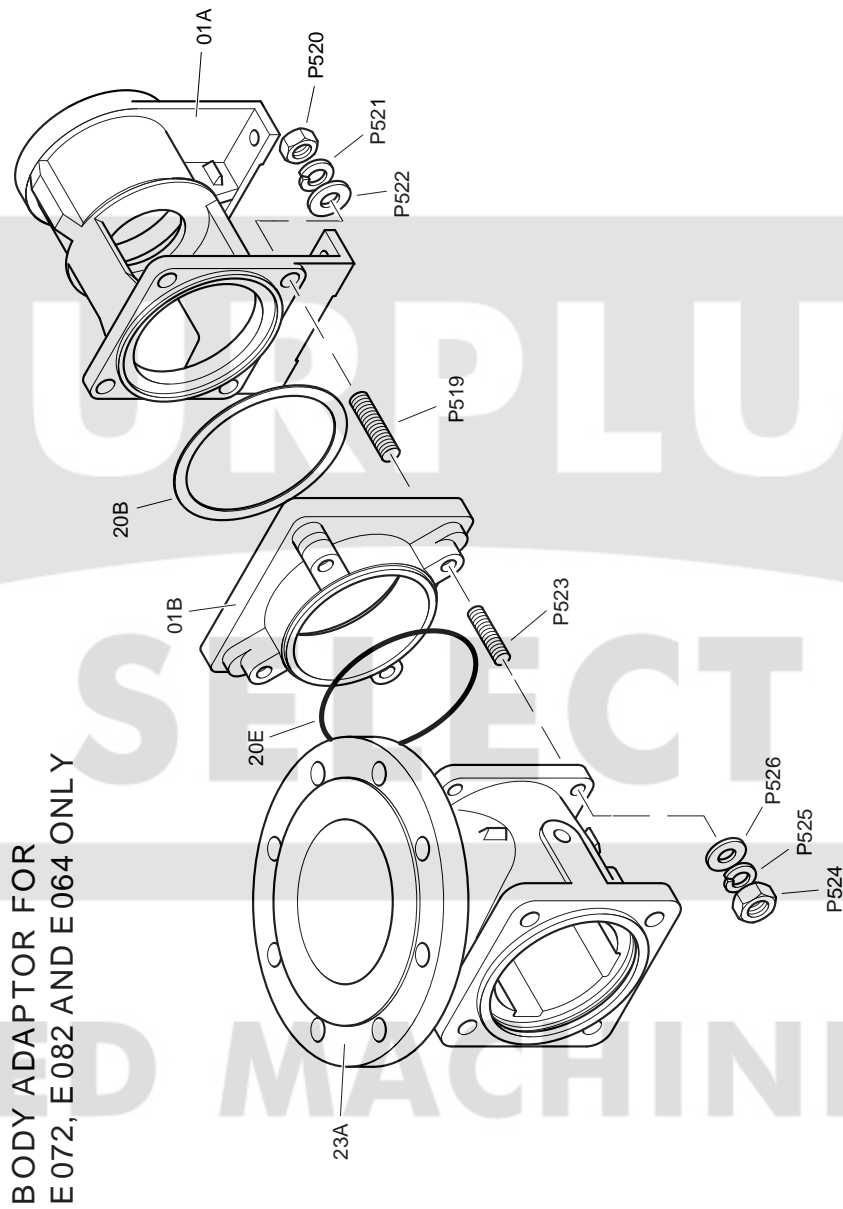

# Exploded Views

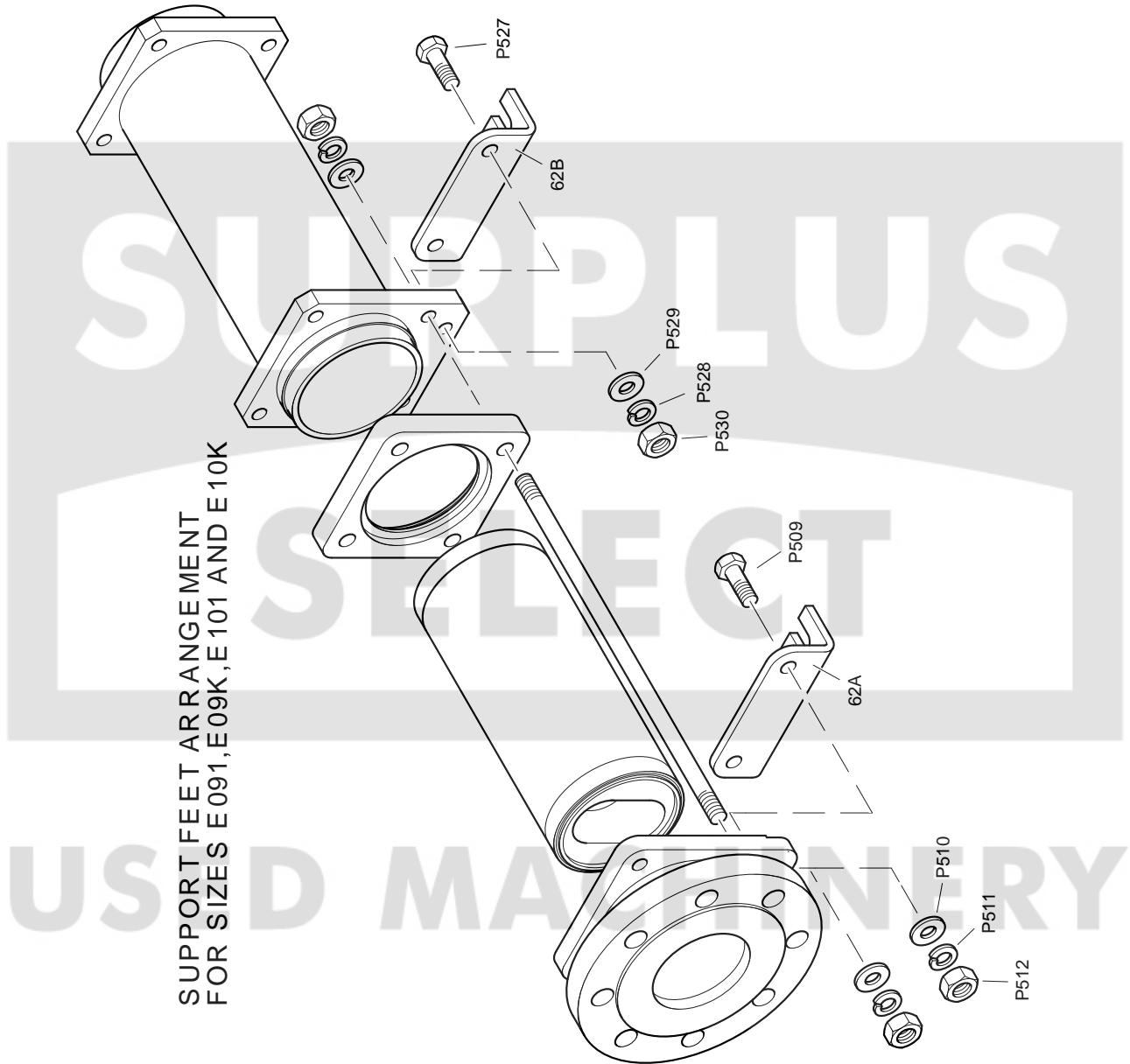



# Exploded Views

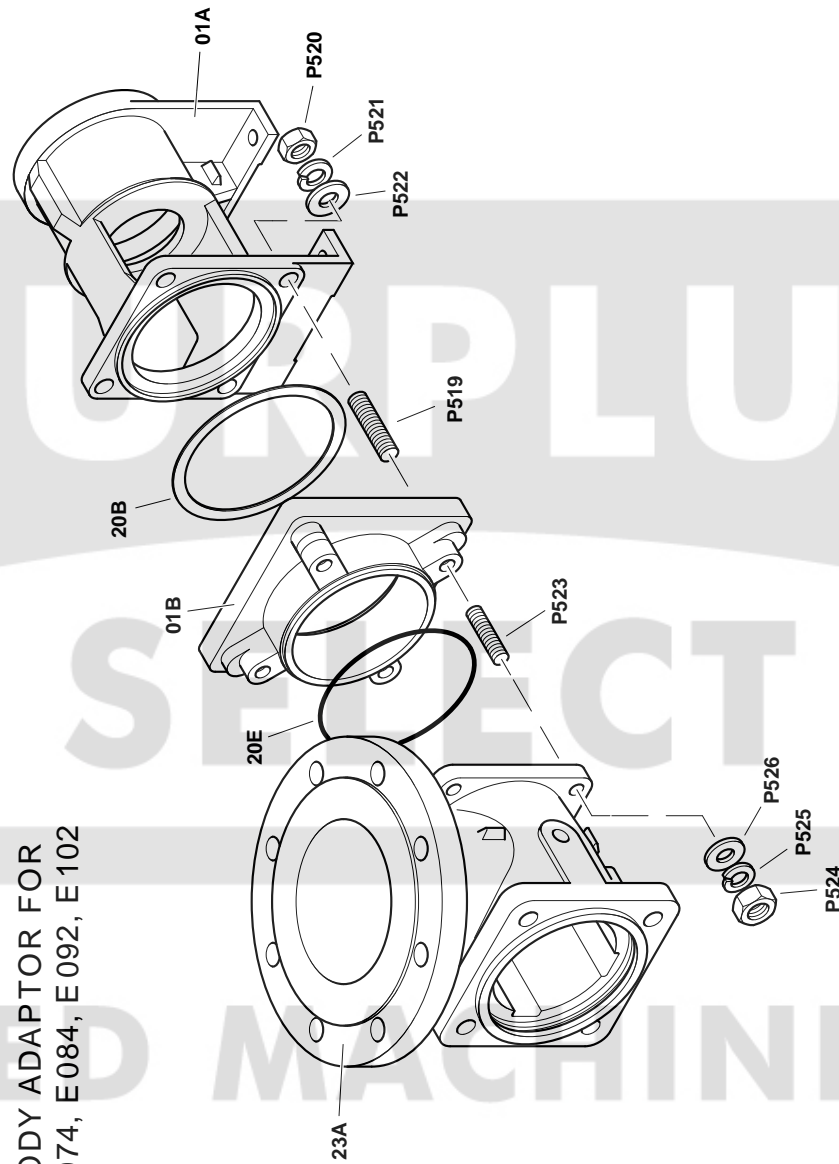

BODY ADAPTOR FOR  
E074, E084, E092, E102

# Exploded Views

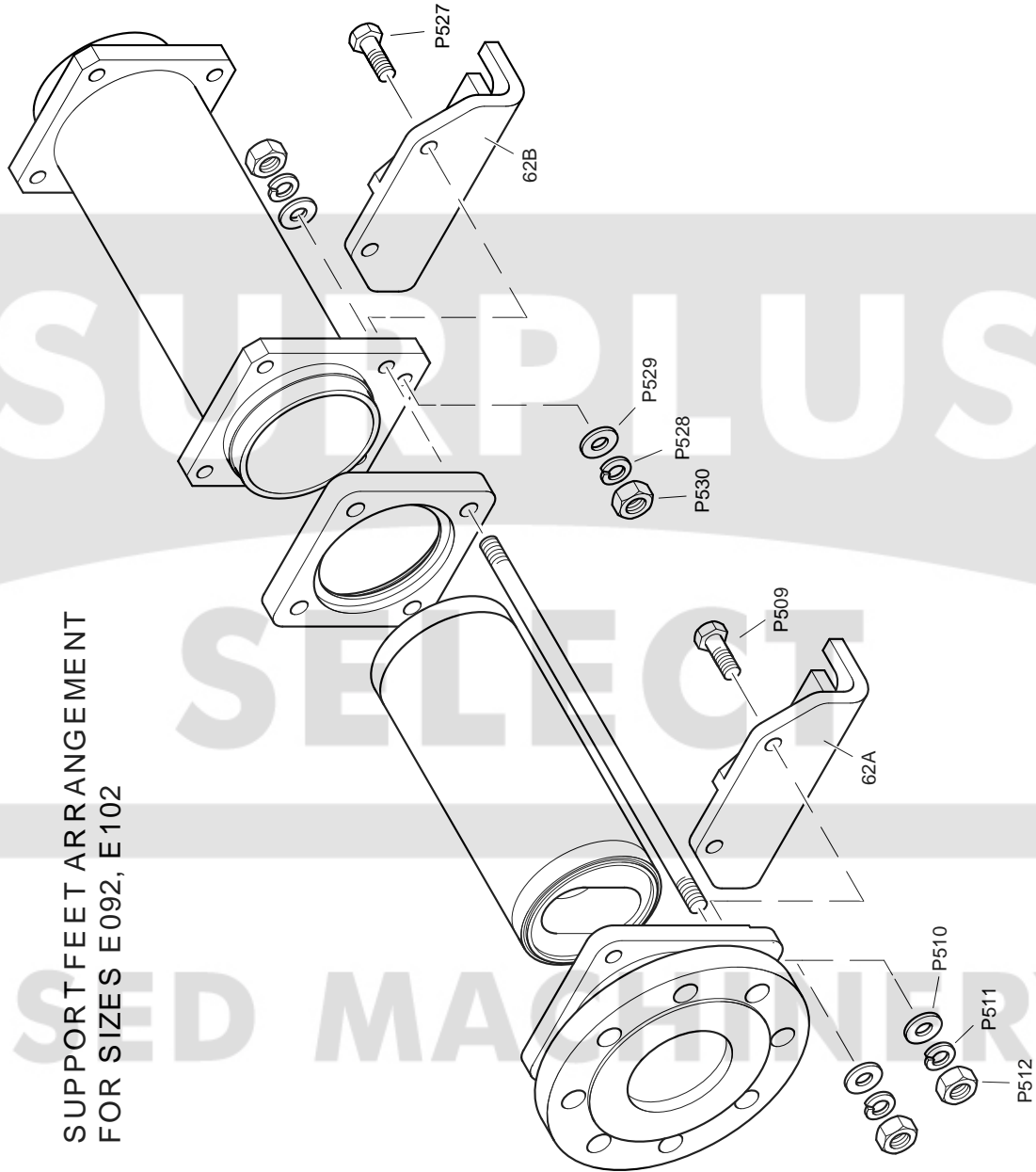

# Exploded Views

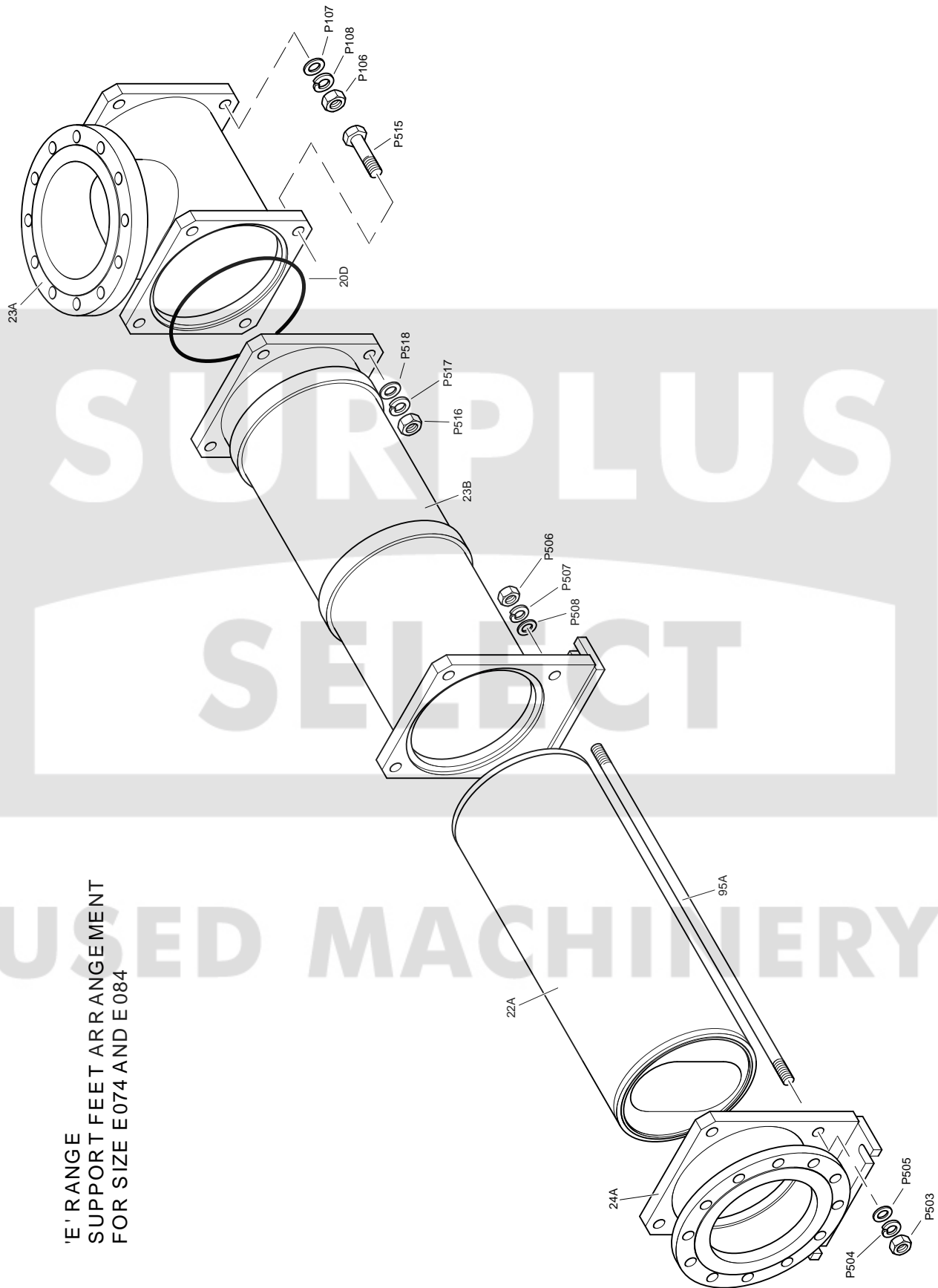

'E' RANGE  
SUPPORT FEET ARRANGEMENT  
FOR SIZE E074 AND E084

# Exploded Views

SUPPORT FOOT ARRANGEMENT  
FOR SIZE E153

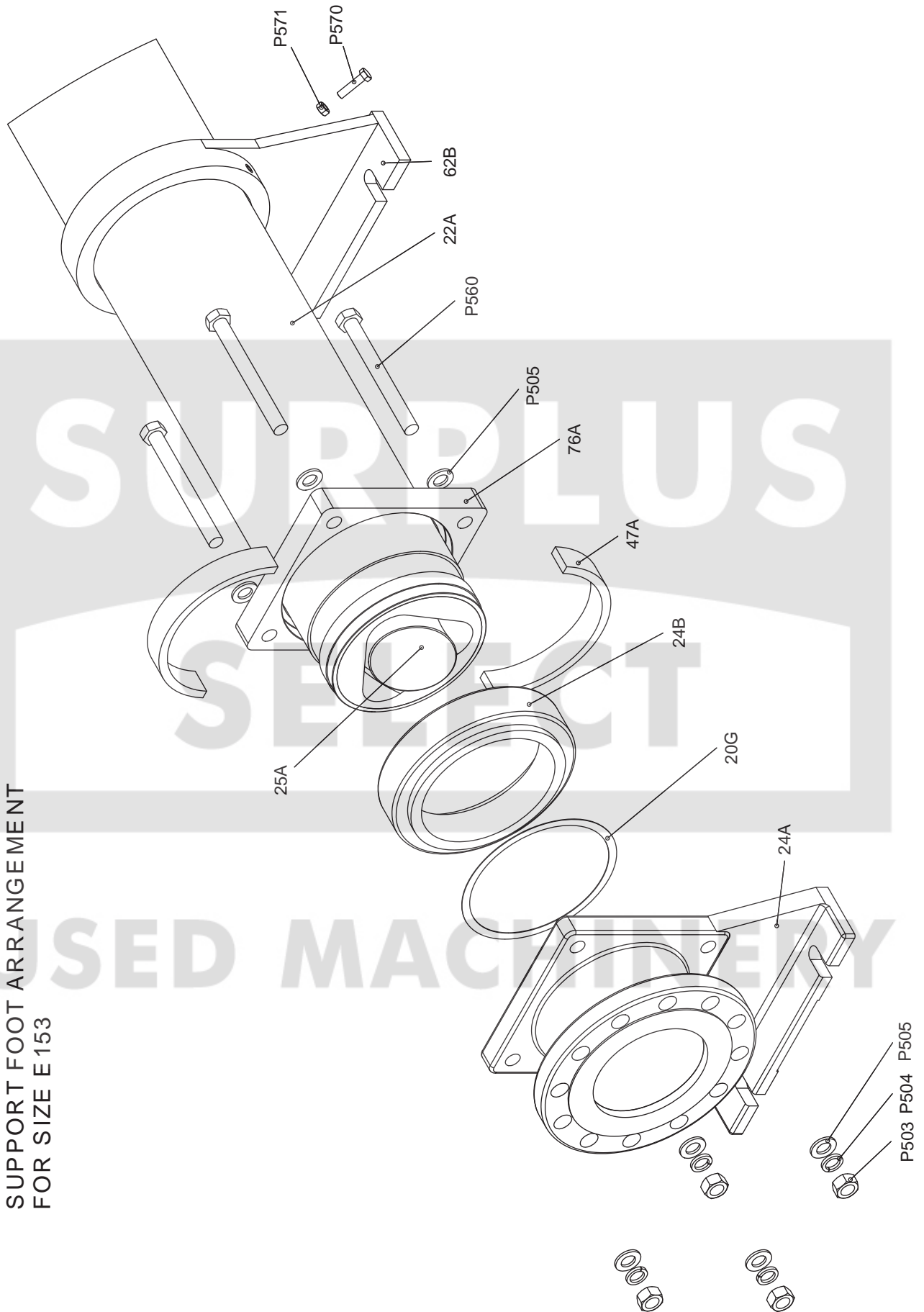



# Exploded Views

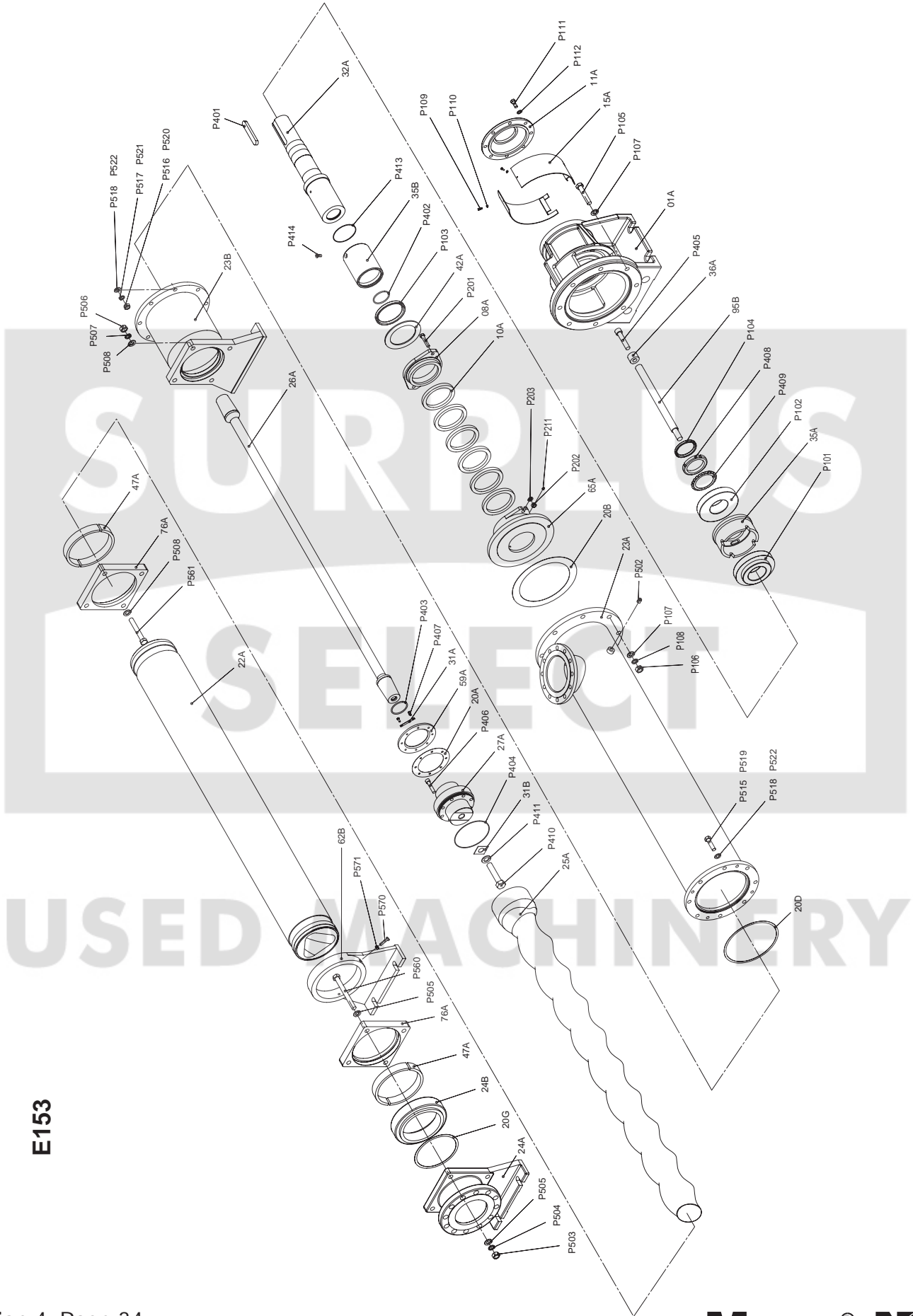

E153



# Exploded Views

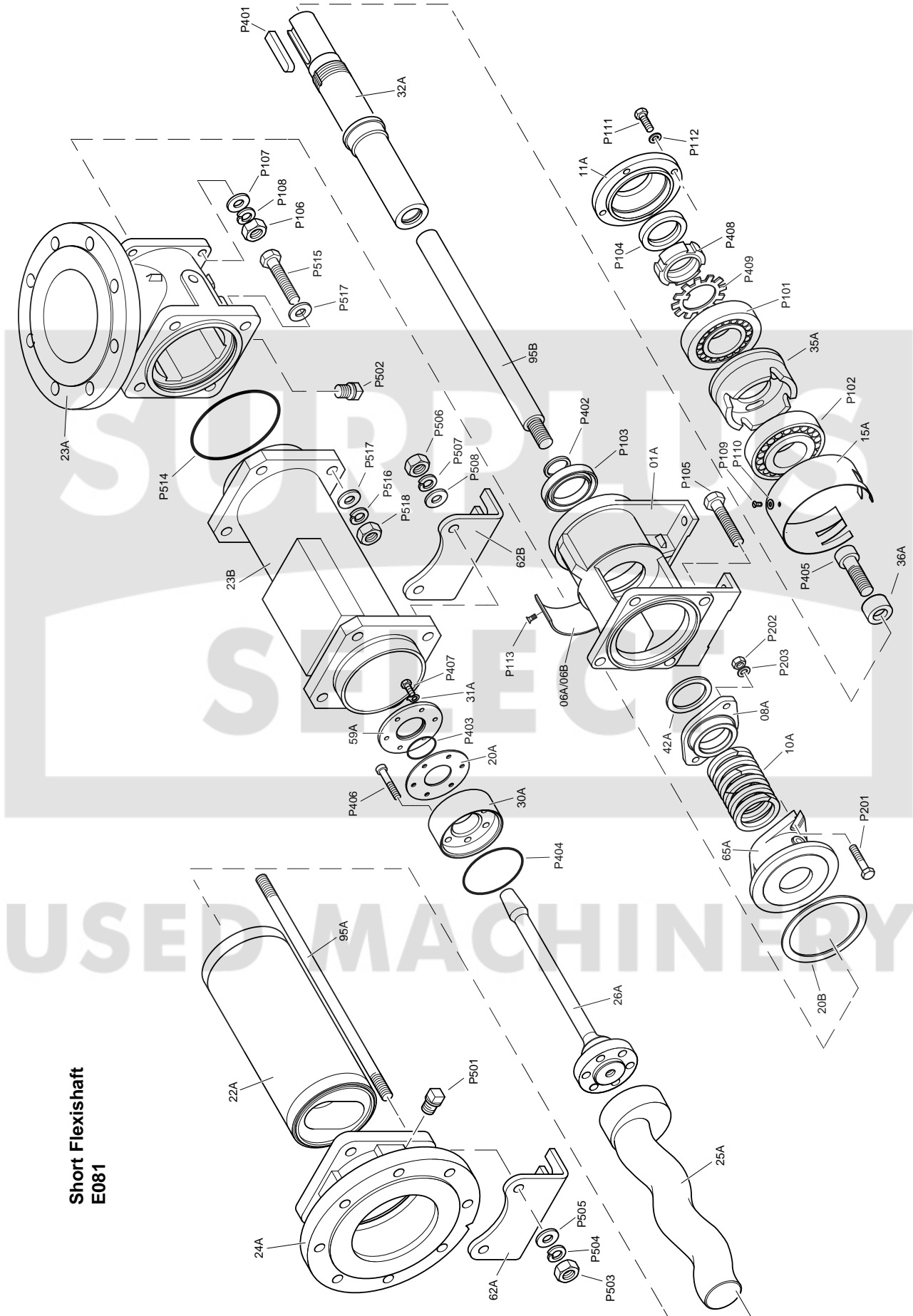

**Short Flexishaft  
E081**

# Exploded Views

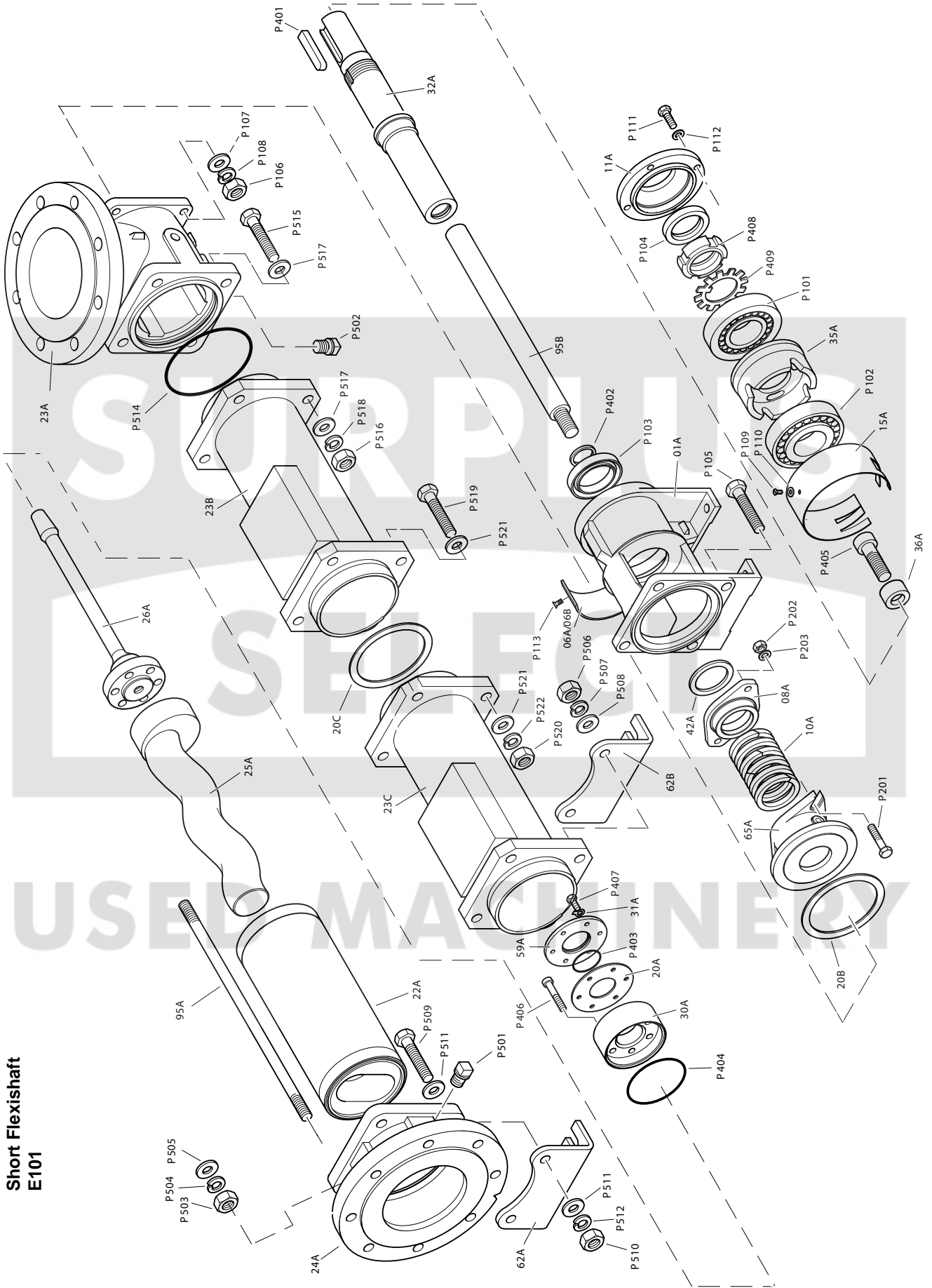

**Short Flexishaft  
E101**

# Torque Tightening Figures

PUMP SIZE	BEARING COVER	BODY / SUCT. CHAMBER	ROTOR HEAD CAP SCREWS	*DRIVE END CAP SCREW	ROTOR HEAD ADAPTOR CENTRE BOLT	COVER PLATE SCREWS	DRIVE END EXTRACTOR TOOL	STATOR TIE BARS/ BOLTS Nm P503 P506 P512 P516 P560, P561
	Nm P111	Nm P105	Nm P406	Nm P405	Nm P410	Nm P407		
E036	9	11	15	27	-	4	75	11
E038	9	11	15	27	-	4	75	11
E0X4	10	16	15	27	-	4	75	10
E041	2	11	15	11	-	4	31	11
E04K	2	11	15	15	-	4	31	11
E042	9	11	15	27	-	4	75	11
E044	9	21	16	53	-	4	149	24
E051	9	11	31	27	-	4	75	11
E05K	9	11	31	27	-	4	75	11
E052	9	21	31	53	-	4	149	11
E054	9	36	37	93	-	4	292	40
E061	9	21	70	53	-	4	149	24
E06K	9	21	70	53	-	4	149	24
E062	9	36	70	93	-	4	292	24
E064	9	90	70	230	-	9	544	75
E071	9	36	74	93	-	4	292	24
E07K	9	36	74	93	-	4	292	24
E072	9	90	74	230	-	4	544	24
E074	17	176	76	450	246	4	1132	75
E081	9	36	128	93	-	9	292	40
E08K	9	36	128	93	-	9	292	40
E082	9	90	128	230	-	9	544	40
E084	17	176	128	450	400	9	1132	120
E091	9	90	128	230	-	9	544	75

**Note:** Torque tolerances are +/-5% of stated nominal figures.

\* Apply thread-locking compound to screw threads prior to assembly.

# Torque Tightening Figures

PUMP SIZE	BEARING COVER	BODY / SUCT. CHAMBER	ROTOR HEAD CAPSCREWS	*DRIVE END CAPSCREW	ROTOR HEAD ADAPTOR CENTRE BOLT	COVER PLATE SCREWS	DRIVE END EXTRACTOR TOOL	STATOR TIE BARS/ BOLTS Nm P503 P506 P512 P516 P560, P561
	Nm P111	Nm P105	Nm P406	Nm P405	Nm P410	Nm P407		
E09K	9	90	128	230	-	9	544	75
E092	17	176	128	450	400	9	1132	75
E101	9	90	128	230	-	9	544	75
E10K	9	90	128	230	-	9	544	75
E102	17	176	128	450	400	9	1132	75
E103	17	176	128	450	400	9	1132	75
E121	17	176	128	450	400	9	1132	120
E12K	17	176	128	450	400	9	1132	120
E122	17	305	320	557	630	9	1404	120
E151	17	305	320	557	630	10	1404	190
E152	17	270	661	1050	1330	10	2625	300
E153	17	305	320	1050	1330	10	2625	300
E161	17	270	320	625	630	10	1404	190
E201	17	270	661	1050	1330	10	2625	300

**Note:** Torque tolerances are +/-5% of stated nominal figures.

\* Apply thread-locking compound to screw threads and male thread of Flexishaft tie bar (95B) prior to assembly.

# Mono Products

## Progressing Cavity (P.C.) Pumps



**E Range**  
Up to 420m<sup>3</sup>/h, 72 bar



**Merlin Ind. Range**  
Up to 60m<sup>3</sup>/h, 10 bar



**LF Range**  
Up to 600l/h, 12 bar



**Monobloc B Range**  
Up to 225m<sup>3</sup>/h, 24 bar



**W Range**  
Up to 215m<sup>3</sup>/h, 48 bar



**S Range**  
Up to 60m<sup>3</sup>/h, 12 bar



**B/G/M Range**  
Up to 3m<sup>3</sup>/h, 5 bar



**Solar Pumps**  
Up to 5.8m<sup>3</sup>/h, 12 bar

# Mono Products

## Grinder / Screens / Extractor Packages



**Mutrator**  
Up to 15m<sup>3</sup>/h

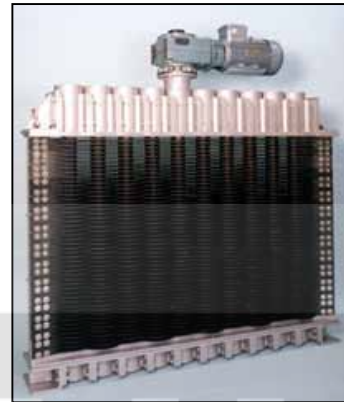

**Discreen**  
Up to 13,400m<sup>3</sup>/h



**Compact Munchpump**  
Up to 25m<sup>3</sup>/h

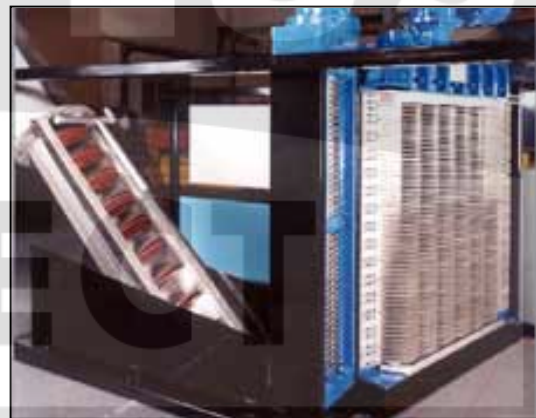

**Screw Extraction Package**  
Up to 13,900m<sup>3</sup>/h



**Macerator**  
Up to 15m<sup>3</sup>/h



**Muncher Family**  
Up to 650m<sup>3</sup>/h



**Grifter**  
Up to 4m<sup>3</sup>/h

# SURPLUS

# SELECT

# USED MACHINERY

## UK and Europe

Mono Pumps Ltd, Martin Street, Audenshaw  
Manchester, M34 5JA, England  
T. +44 (0)161 339 9000  
E. [info@mono-pumps.com](mailto:info@mono-pumps.com)

## USA

Monoflo Inc., 10529 Fisher Road  
Houston, Texas 77041, USA  
T. +1 713 980 8400  
E. [inquire@monoflo.com](mailto:inquire@monoflo.com)

## Australasia

Mono Pumps (Australia) Pty Ltd  
Mono House, 338-348 Lower Dandenong Road  
Mordialloc, Victoria 3195, Australia  
T. +61 (0)3 9580 5211  
E. [ozsales@mono-pumps.com](mailto:ozsales@mono-pumps.com)

Mono Pumps (New Zealand) Ltd  
PO Box 71-021, Fremlin Place, Avondale  
Auckland 7, New Zealand  
T. +64 (0)9 829 0333  
E. [info@mono-pumps.co.nz](mailto:info@mono-pumps.co.nz)

## Asia

Mono Pumps Ltd, No. 500 YaGang Road  
Lujia Village, Malu, Jiading District  
Shanghai 201801, P.R. China  
T. +86 (0)21 5915 7168  
E. [monoshanghai@nov.com](mailto:monoshanghai@nov.com)

[www.mono-pumps.com](http://www.mono-pumps.com)

**Mono<sup>®</sup> NOV**

One Company, Unlimited Solutions